



Manufacturers G100 Product Declaration

Declaration of Conformity in line with Engineering Recommendation G100

SolaX Power Network Technology (Zhe jiang) Co. , Ltd.

Hereby confirms that **X3-Fit** Series inverter(the model shown as below) complies with the power meter (&CTs) recommended by SolaX Power, Engineering Recommendation G100 Issue 1 Amendment 2 2018, Technical Guidance for Customer Export Limiting Schemes, when installed in accordance with this Engineering G100 Declaration.

(Note:only Support CHNT DTSU666 Power Meter)

This Declaration should be read in conjunction with the inverter user manuals and meter quick installation guide.

X3-Fit-8.0E	X3-Fit-8.0C	X3-Fit-10.0E	X3-Fit-10.0C
X3-Fit-6.0-W	X3-Fit-8.0-W	X3-Fit-10.0-W	X3-Fit-15.0-W
X3-Fit-6.0-M	X3-Fit-8.0-M	X3-Fit-10.0-M	X3-Fit-15.0-M



1. Introduction

Engineering Recommendation G100: Technical Guidance for Customer Export Limiting Schemes “defines the technical design requirements for Export Limitation Schemes which limit the net site export to below an agreed maximum and are installed on the Customer’s side of the Connection Point”.

While G100 does not describe a type test procedure, it does describe a number of system requirements. This document describes how an **X3-Fit** installation performs relative to key G100 requirements.

2. Description of Operation

A description of the scheme, its settings, and a single line diagram should be permanently displayed on site.

SolaX Power **X3-Fit** inverter can be set the export limiting power on the inverter LCD display based on customer or local rules requirements. SolaX Power named this function “export control” on LCD display and it can be can be set from

0-300000W. This function means customer should install a meter(power monitoring unit) to monitor energy exported to or imported from the grid.

Note: Please see section 9 of specific LCD display operation.

After setting the export limit power, the system switches between 3 operational states:

- Charging: **X3-Fit** charges when site-export is detected, to minimise electricity exported to the grid (loads less than solar generation)
- Discharging: **X3-Fit** discharges when site-import is detected, to minimise electricity import from the grid (loads greater than solar generation)
- Idle: No charge or discharge (battery full/flat or no solar/load)

A fundamental principle of this operation is that energy stored in the battery is only released to run loads within the building - at no time is the system attempting to export battery energy to the grid. This control is achieved by:

Meter (Power Monitoring Unit)

- The “Meter” - a power meter (& CTs) recommended by SolaX Power.
- Measures power flowing in/out of the home and sends this data to inverter.
- Connected to the inverter via a communication cable

3. Power Quality Requirements

Where the **X3-Fit** relies on power electronics (e.g. Converters etc) to control the load it shall also provide information demonstrating compliance with relevant harmonics standards (e.g. BSEN 61000-3-2 and/or BSEN 61000-3-12) or provide data on the harmonic produced in accordance with ER G5.

Please confirm product complies with relevant harmonic standards:

SolaX Power Network Technology (Zhe jiang) Co. , Ltd. confirms that **X3-Fit** complies with the requirements of the relevant harmonics standards and that the relevant harmonic data has been provided as required by ER G5.

4. System Schematic

A **X3-Fit** installation is formed of four main elements:

1. Main elements:
 - A *X3-Fit*
 - A *SOLAX Meter*
 - A *Battery Modules*
2. System Schematic:

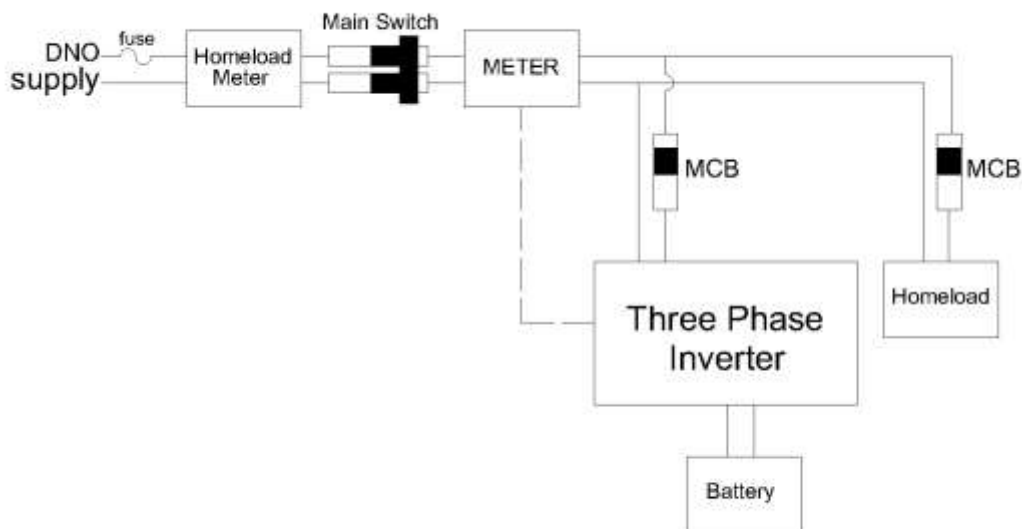

5. Component Interconnection/Fail Safe Operation

The ELS may be formed of discrete units or integrated into a single packaged scheme. Where discrete units are used they should preferably be interconnected using metallic or fibre optic cables. Alternatively the units may be interconnected using secure radio links but where this is the case these links should be licensed (by OFCOM) and have a planned availability of 99.9% or higher. Irrespective of the media used for interconnecting between the discrete units, if the communication path fails the generation output should be reduced to a nominal value stipulated by the DNO within a set response time to prevent the Agreed Export Capacity from being exceeded.

5.1 Describe Component Interconnection

The system is made up of multiple discrete components. Each component of the system communicates via galvanically connected metallic cables.

As shown in the diagram below, communication between all parts of the system can be wired.



5.2 System fail-safe test results

No	Test	System Response	Time	Pass
1	Disconnection of power to meter	Unplug communications cable between Inverter and Meter	<5s	Y
2	Remove power supply to Meter	Remove power supply to Meter	<5s	Y
3	Inverter response time	Under normal operating conditions, The Pgrid value is reduced to 0W Inverter response time.	<5s	Y
4	Inverter response time	Under normal operating conditions, The Pgrid value is reduced to 2000W Inverter response time.	<5s	Y

5.2.1 Unplug communications cable between Inverter and Meter

Test result:

- Test: Unplug communications cable between Inverter and Meter
- Scope: Pink trace is RS485 communications from the Meter.
Yellow shows current at output of AC current.
- Reaction time: 4.12s
- Pass/fail: PASS

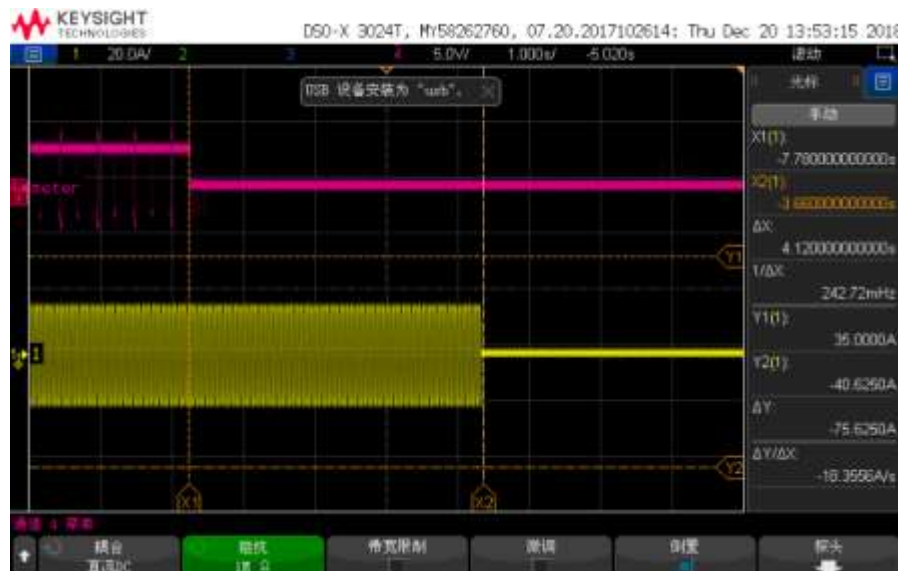

Test result:

- Test: Unplug communications cable between Inverter and Meter
- Scope: Pink trace is CAN communications from the Battery.
Yellow shows current at output of EPS current.
- Reaction time: 4.10s
- Pass/fail: PASS

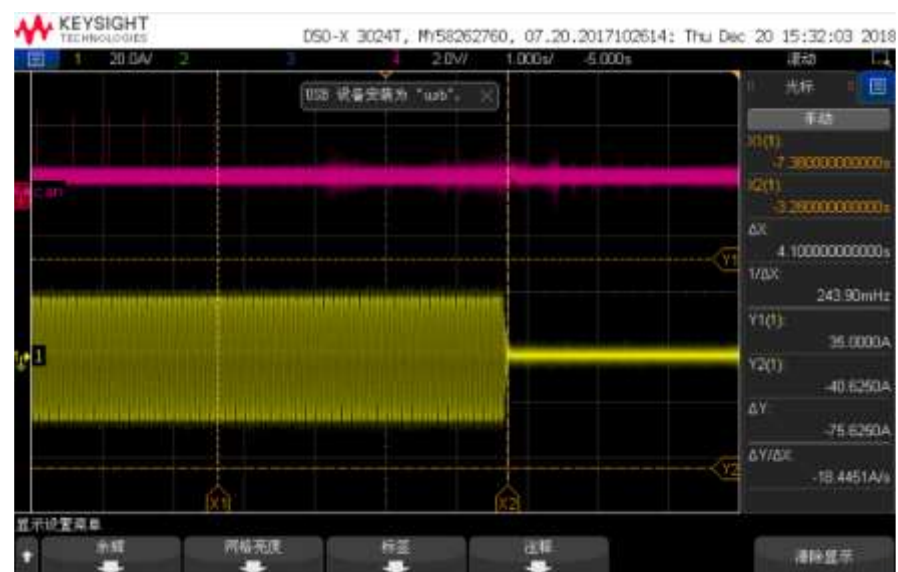

5.2.2 Remove power to meter

Test result:

- Test: Remove 230V AC supply to meter
- Scope: Blue trace is AC voltage to Meter, Yellow shows current at output of AC current
- Reaction time: 4.24s
- Pass/fail: PASS



5.2.3 Under normal operating conditions, The Pgrid value is reduced to 0W Inverter response time.

The inverter is connected to the maximum load.

Turn on the load switch so that the Pgrid value is equal to zero.

Then turn off the load switch and observe the time required for the grid current to be limited to 0A.

Test result:

- Test: Set user value to 0W, The Pgrid value is reduced to 0W within 5 seconds
- Scope: Blue trace is AC current of load, Pink shows current at output of AC current.
- Pass/fail: PASS

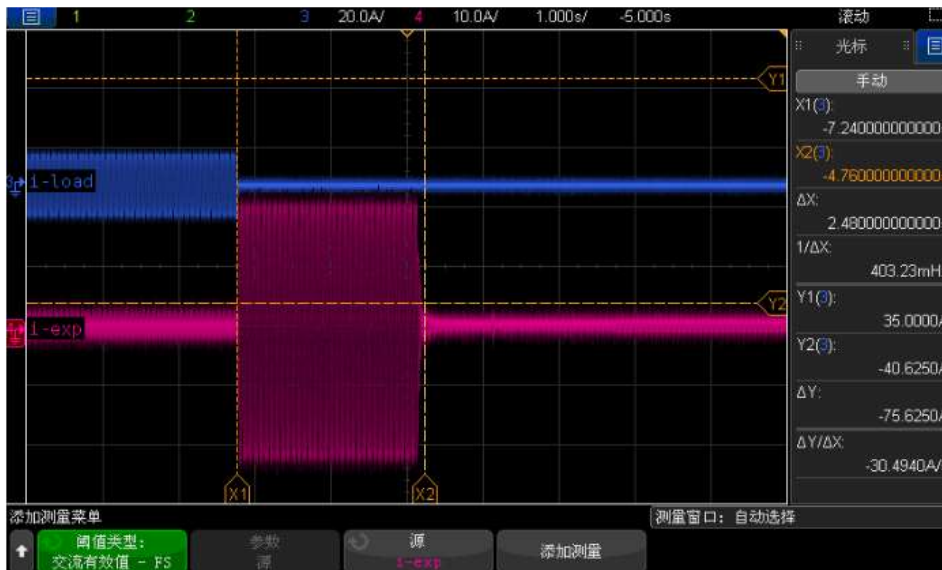

Test Category: Only the Battery Reaction time: 2.48S

5.2.4 Under normal operating conditions, The Pgrid value is reduced to 5000W Inverter response time.

The inverter is connected to the maximum load.

Turn on the load switch so that the Pgrid value is equal to zero.

Then turn off the load switch and observe the time required for the grid current to be limited to 0A.

Test result:

- Test: Set user value to 5000W. The Pgrid value is reduced to 5000W within 5 seconds.
- Scope: Blue trace is AC current of load, Pink shows current at output of AC current.
- Pass/fail: PASS



Test Category: Only the Battery Reaction time: 2.72S

6. Accuracy & Response time

The overall accuracy of **ELS** with regard to measurement and control of Active Power and, where applicable, Voltage, shall be determined by the manufacturer of the system and published within its operating manual. The **X3-Fit** has been tested for the following function errors:

Test	Result
Sensing passed test	Yes
Measurement passed test	Yes
Processing passed test	Yes
Communication passed test	Yes
Control passed	Yes
Environmental factors passed test	Yes
Operating Manual is available	Yes
The settings applied to X3-Fit have taken account of the published tolerances to ensure the required export limits and voltage limits will be maintained.	Yes

The ELS must detect an excursion and reduce the export to the Agreed Export Capacity or less within 5 seconds.

- Under normal operating conditions, **X3-Fit** response time is less than 5s
- Under loss of communications, or loss of power to Meter/Gateway, response time is less than 5s

7. Password Protection

Once installed and commissioned, the scheme settings should not be capable of being readily altered by the Customer and should only be changed with the written agreement of the DNO.

All **X3-Fit** settings are password protected and cannot be altered by the customer.

8. X3-Fit G100 Installation Requirements

- Make sure that the inverter is fixed on the wall.
- Ensure that all ground wires are grounded.
- Confirm that all DC lines and AC lines are connected.
- Make sure the CT is connected.
- Make sure the battery is well connected.
- Turn on the Load switch and EPS(Off-grid) switch.
- Turn on the Battery Switch.

9. LCD display operation

Customer should set “export control” function on the LCD display. “Export Control” setting can be found according to path below.

- Menu —Setting —Advanced —On-grid —Export Control.

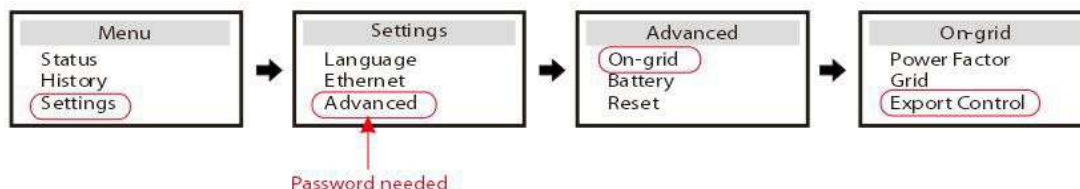

- This value can be set from 0-300000W.
For example, if it is set 0W, it means no power can be exported to the grid; If it is set 4000W, it means the power exported to the grid can not exceed 4000W.



10. Contact information

Name: Xiao Yongli

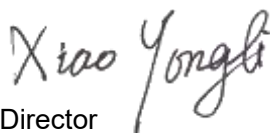

Title: R&D Technical Director

Date: 2022-11-9