

SAJ



GUANGZHOU SANJING ELECTRIC CO.,LTD



Tel: (86)20 66608588 Fax: (86)20 66608589 Web: www.saj-electric.com

Add: SAJ Innovation Park, No.9, Lizhishan Road, Science City, Guangzhou High-tech Zone, Guangdong, P.R.China

V1.1

SAJ



B2 Series

RECHARGEABLE LI-ION BATTERY MODULE

USER MANUAL

B2-5.0-LV1 B2-5.0-LV2

Preface

Thank you for choosing SAJ battery. We are pleased to provide you first-class products and exceptional service.

This manual includes information for installation, operation, maintenance, trouble shooting and safety. Please follow the instructions of this manual so that we can ensure delivery of our professional guidance and wholehearted service.

Customer-orientation is our forever commitment. We hope this document proves to be of great assistance in your journey for a cleaner, greener world.

Please check for the latest version at www.saj-electric.com

Guangzhou Sanjing Electric Co., Ltd.



TABLE OF CONTENTS

1. SAFETY PRECAUTIONS	1
1.1 Application Scope	2
1.2 Safety Instructions	2
1.3 Target Group	2
2. PREPARATION	3
2.1 Safety Instructions	4
2.2 Explanations Of Symbols	5
2.3 Battery Handling	6
2.4 Emergency Situation	6
3. PRODUCT INFORMATION	9
3.1 Application Typology Diagram	10
3.2 Product Model	10
3.3 Dimensions	11
3.4 Component Description	11
3.5 Datasheet	12
4. INSTRUCTIONS FOR INSTALLATION	15
4.1 Unpacking and Inspection	16
4.1.1 Checking the Package	16
4.1.2 Scope of Delivery	16

4.2 Installation Requirements	17
4.2.1 Position and Clearance	17
4.2.2 Mounting Method	18
4.2.3 Environment Requirements	18
4.3 Mounting Procedure	19
4.3.1 Installation Tools	19
4.3.2 Mounting Procedure	19
5. ELECTRICAL CONNECTION	27
5.1 Additional Grounding Cable	28
5.2 Connecting Communication Cable	30
5.3 Connecting Power Cable	33
5.4 Connecting Battery to Inverter	35
5.5 Pinout Description of RJ45	37
5.6 Installation of Side Covers	38
6. COMMISSIONING	39
6.1 Start Up and Shut Down	40
6.1.1 Start Up	40
6.1.2 Shut Down	40
6.2 Introduction of Display	41
6.3 Commissioning	42
7. Transportation and Storage	43
7.1 Transportation	44
7.2 Storage	44
7.3 Maintenance	45
8. Troubleshooting and Warranty	47

1.1 Application Scope

This User Manual describes instructions and detailed procedures for installing, operating, maintaining, and troubleshooting of the following SAJ products:

B2-5.0-LV1; B2-5.0-LV2

1.2 Safety Instructions

 **DANGER**

· DANGER indicates a hazardous situation which, if not avoided, will result in death or serious injury.

 **WARNING**

· WARNING indicates a hazardous situation which, if not avoided, can result in death or serious injury or moderate injury.

 **CAUTION**

· CAUTION indicates a hazardous condition which, if not avoided, can result in minor or moderate injury.

 **NOTICE**

· NOTICE indicates a situation that can result in potential damage, if not avoided.

1.3 Target Group

Only qualified electricians who have read and fully understood all safety regulations in this manual can install, maintain and repair the battery.

1.

SAFETY PRECAUTIONS



2.

PREPARATION



2.1 Safety Instructions

For safety, be sure to read all the safety instructions carefully prior to any works, and please observe the appropriate rules and regulations of the country or region where you installed B2 battery.

DANGER

- Please keep the power off prior to any operations
- Do not use the battery or the battery control unit if it is defective, broken or damaged.
- Do not expose the battery to temperatures in excess of 50°C.
- Do not subject the battery to any strong force.
- Do not place the battery near a heat source, such as direct sunlight, a fireplace.
- Keep inflammable and explosive dangerous items or flames away from the battery.
- Do not soak the battery in water or expose it to moisture or liquids.
- Do not use the battery in vehicles.

WARNING

- Only qualified personnel who has full knowledge of local safety regulations and local standards on battery can install, maintain, retrieve and process this product.
- SAJ electric shall not be liable for any loss or warranty claims arising from any unauthorized change of product which may cause fatal injury to the operator, third party or equipment performance.
- For personal and property safety, do not short-circuit the positive (+) and negative (-) electrode terminals.









CAUTION

- Do not modify or change any components in the battery.
- Risk of damage due to improper modification
- Use professional tools when operating the products.

NOTICE

- During installation of the B2 low voltage battery, circuit breaker must be disconnected from the battery pack wiring.
- The battery can only be used as a set with SAJ's H1 series hybrid solar inverter, otherwise it cannot be used normally.

2.2 Explanations of Symbols

Symbol	Description
	Dangerous electrical voltage This device is directly connected to public grid, thus all work to the battery shall only be carried out by qualified personnel.
	No open flames Do not place or install near flammable or explosive materials.
	Danger of hot surface The components inside the battery will release a lot of heat during operation. Do not touch metal plate housing during operating.
	Attention Install the product out of reach of children.
	An error has occurred. Please go to Chapter 7 "Troubleshooting" to remedy the error.
	This device shall NOT be disposed of in residential waste.
	This battery module shall NOT be disposed of in residential waste.
	CE Mark Equipment with the CE mark fulfills the basic requirements of the Guideline Governing Low-Voltage and Electro-magnetic Compatibility.
	Recyclable

2.3 Battery Handling

Operate and use the battery properly according to user manual, any attempt to modify battery without the permission from SAJ will void the limit warranty for the battery.

- The battery must be installed at a suitable location with sufficient ventilation.
- Do not use the battery if it is defective, damaged, or broken.
- Only use the battery with the compatible inverter.
- Do not use the battery with other types of battery.
- Make sure the battery is grounded prior to use.
- Do not pull out any cables or open the battery enclosure when the battery is powered on.
- Only use the battery as intended and designed.

2.4 Emergency Situation

Despite of its careful and professional protection design against any hazards, damage of the battery may still possible. If a small amount of battery electrolyte is released due to a serious damage of the outer casing; or if the battery explodes due to not being treated timely after a fire breaks out nearby, and leaks out poisonous gases such as carbon monoxide, carbon dioxide and etc., the following actions are recommended:

- 1) Eye contact: Rinse eyes with a large amount of running water and seek medical advice.
- 2) Contact with skin: Wash the contacted area with soap thoroughly and seek medical advice.
- 3) Inhalation: If you feel discomfort, dizziness or vomiting, seek medical advice immediately.
- 4) Use a FM-200 or Carbon Dioxide (CO₂) fire extinguishers to extinguish the fire if there is a fire in the area where the battery pack is installed. Wear a gas mask and avoid inhaling toxic gases and harmful substances produced by the fire.
- 5) Use an ABC fire extinguisher, if the fire is not caused by battery and not spread to it yet.

⚠ WARNING

·If a fire has just occurred, try to disconnect the battery circuit breaker and cut off the power supply first, but only if you can do so without endangering yourself.

·If the battery is on fire, do not attempt to extinguish the fire but evacuate the crowd immediately.

Potential danger of damaged battery:

Chemical Hazard: Despite of its careful and professional protection design against any hazard results, rupture of battery may still occur due to mechanical damage, internal pressure etc., and may result in a leakage of battery electrolyte. The electrolyte is corrosive and flammable. When there is fire, the toxic gases produced will cause skin and eyes irritation, and discomfort after inhalation. Therefore:

- 1) Do not open damaged batteries;
- 2) Do not damage the battery again (shock, fall, trample, etc.);
- 3) Keep damaged batteries away from water (except to prevent an energy storage system from catching fire);
- 4) Do not expose the damaged battery to the sun to prevent internal heating of the battery.

Electrical hazard: The reason of fire and explosion accidents in lithium batteries is battery explosion. Here are the main factors of battery explosion:

1) Short circuit of battery. Short circuit will generate high heat inside battery, resulting in partial electrolyte gasification, which will stretch the battery shell. The temperature reaching ignition point of internal material will lead to explosive combustion.

2) Overcharge of battery. Overcharge of battery may precipitate lithium metal. If the shell is broken, it will come into direct contact with the air, resulting in combustion. The electrolyte will be ignited at the same time, resulting in strong flame, rapid expansion of gas and explosion.



3.

PRODUCT INFORMATION



3.1 Application Typology Diagram

The B2 series low voltage battery is applied to residential photovoltaic storage system. The battery is equipped with a built-in battery management system (BMS), which functions to ensure efficiency of the battery and protect the battery from operating out of its specified limitations. The battery employs modular design for easy installation and wiring.

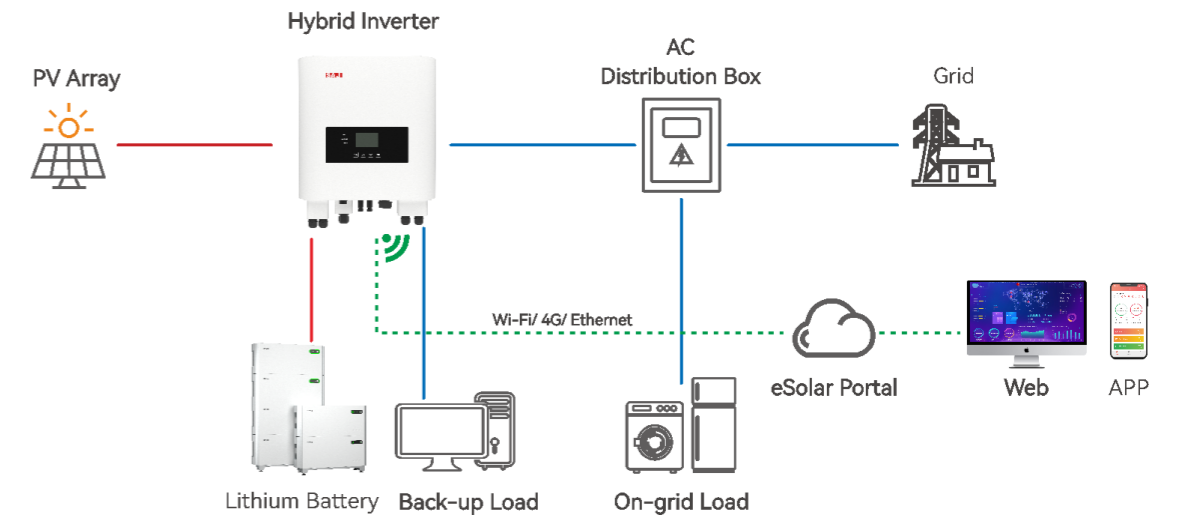

Figure 3.1
Application typology diagram

3.2 Product Model

B2 - **X.X** - **LV1/2**
 ① ② ③

①B2 represents for product name.

②X.X represents rated energy X kWh of battery, for example, 5.0 means 5.0kWh.

③LV means low voltage, 1/2 represents different battery cell manufacturers.

3.3 Dimensions

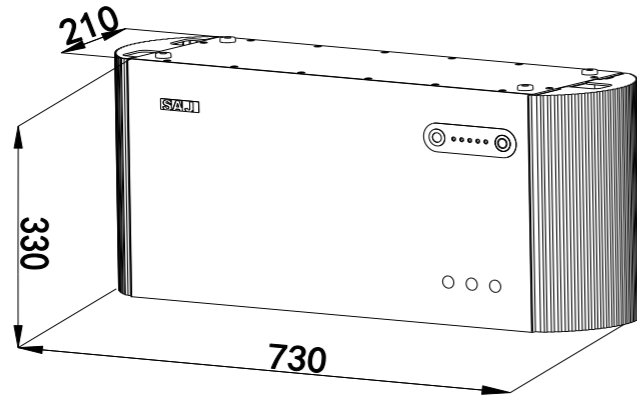

Figure 3.2
Dimensions of battery (unit: mm)

3.4 Component Description

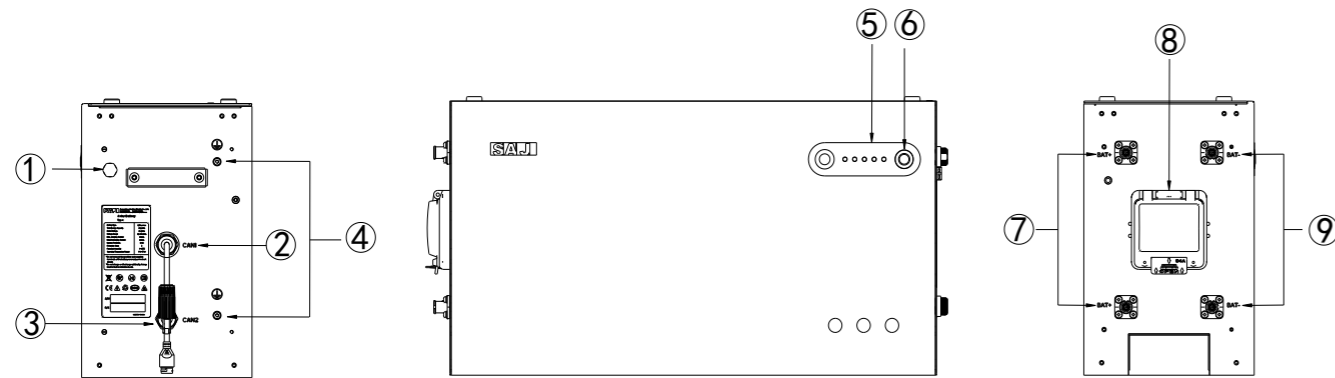

Figure 3.3
Components of battery

Callout	Name
①	Breather valve
②	CAN1
③	CAN2
④	Ground
⑤	Display
⑥	Main switch
⑦	BAT+ port
⑧	Circuit breaker
⑨	BAT- port

Table 3.1
Battery components description

3.5 Datasheet

Model	B2-5.0-LV1	B2-5.0-LV2
Electrical parameters		
Total energy capacity [kWh]	5.0	5.0
Usable capacity [kWh]	4.5	4.5
Rated voltage [V]	51.2	
Voltage range [V]	44.8 ~ 57.6	
Depth of discharge [DOD]	≤ 90%	
Max. charge current [A]	100	100
Max. discharge current [A]	100	100
Parallel	Yes (≤8pcs)	
Battery Designation	IFpP52/161/120[(1P16S)nS]M/-20+40/90, n=number of modules	IFpP51/161/120[(1P16S)nS]M/-20+60/90, n=number of modules
Physical parameters		
Battery cell type	LiFePO4	
Communication	CAN	

Model	B2-5.0-LV1	B2-5.0-LV2
Operating temperature	Charging: 0 ~ 50°C; Discharging: -10 ~ 50°C	
Storage temperature	-20~45°C (≤1 month); 0~35°C (≤6 months)	
Cooling method	Natural convection	
Ambient humidity	0 ~ 95% non-condensing	
Operating altitude [m]	≤2000	
Ingress Protection	IP65	
Installation type	Wall-mounted or ground-mounted installation	
Dimensions [H*W*D][mm]	330*730*210	
Weight [kg]	45.7	47.5
Warranty [Year]	Refer to the warranty card	
Applicable standard	IEC62619(Cell&Pack), EN62477-1, EN61000-6-1/2/3/4, UN38.3	



4.

INSTRUCTIONS FOR INSTALLATION



4.1 Unpacking and Inspection









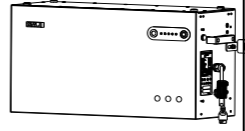

4.1.1 Checking the Package

Although SAJ's batteries have thoroughly tested and checked before delivery, the battery may suffer damages during transportation. Please check the package for any obvious signs of damage, and if such evidence is present, do not open the package and contact your dealer as soon as possible.

4.1.2 Scope of Delivery

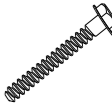
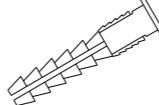
Please contact after sales if there are missing or damaged components.

Battery Module Package

			
Battery control unit*1	Side cover*1	Side cover*1	Locking bracket*2
			
M4*10 screw*8	M4*20 screw*4	Grounding cable*1	M6*50 screw*2
			
Screw fixing seat*2	Flat gasket*2	Power cable*1	Power cable*1
			
Documents			

4.2 Installation Requirements

4.2.1 Position and Clearance

This device is cooled by natural convection and suggested an indoor installation or an installation under a sheltered place to prevent the battery from exposure to direct sunlight, rain and snow erosion.

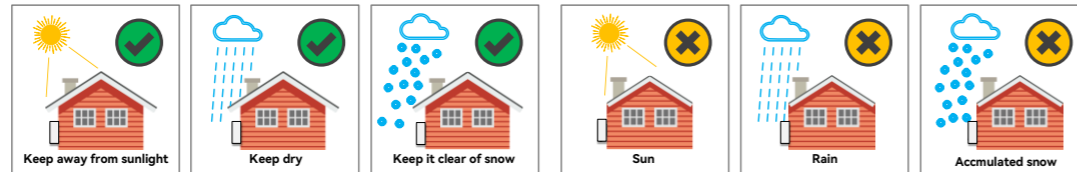

Figure 4.1
Installation location

Please reserve enough clearance around the battery to ensure a good air circulation at the installation area. Because poor air ventilation will affect the working performance of internal electronic components and shorten the service life of the system.

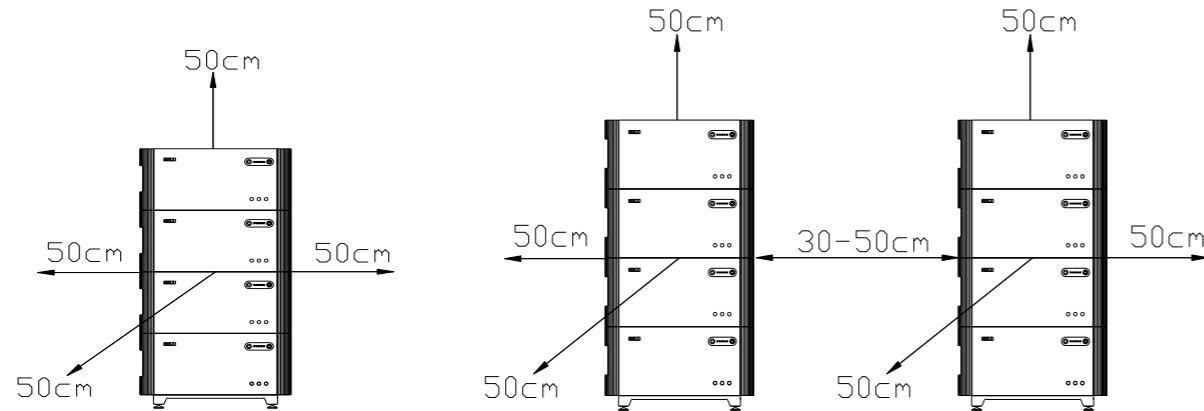

Figure 4.2
Installation space

4.2.2 Mounting Method

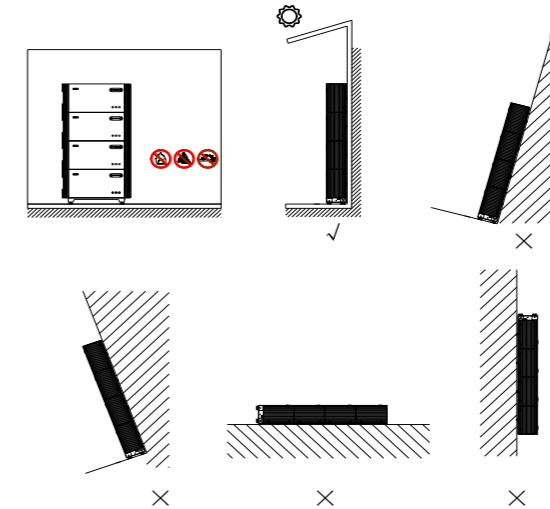

Figure 4.3
Mounting method

- ① The equipment employs natural convection cooling, and it can be installed indoor or outdoor.
- ② Mount vertically. Never install the battery tilted forwards, sideways, horizontally or upside down.
- ③ When mounting the battery, please consider the solidity of wall for battery, including accessories, make sure the wall has enough strength to hold the screws and bear the weight of products. Please ensure the mounting bracket mounted tightly.

4.2.3 Environment Requirements

- The installation environment must be free of inflammable or explosive materials.
- Install the battery away from heat source.
- Do not install the battery at a place where the temperature changes extremely.
- Keep the battery away from children.
- Do not install the battery at daily working or living areas, including but not limited to the following areas: bedroom, lounge, living room, study, toilet, bathroom, theater and attic.

- When installing the battery at the garage, please keep it away from drive way.
- Keep the battery from water sources such as taps, sewer pipes and sprinklers to prevent water seepage.

Note: When installing outdoors, the height of the battery from the ground should be considered to prevent the battery from soaking in water. The specific height is determined by the site environment.

4.3 Mounting Procedure

4.3.1 Installation Tools

Installation tools include but are not limited to the following recommended ones. Please use other auxiliary tools on site if necessary.

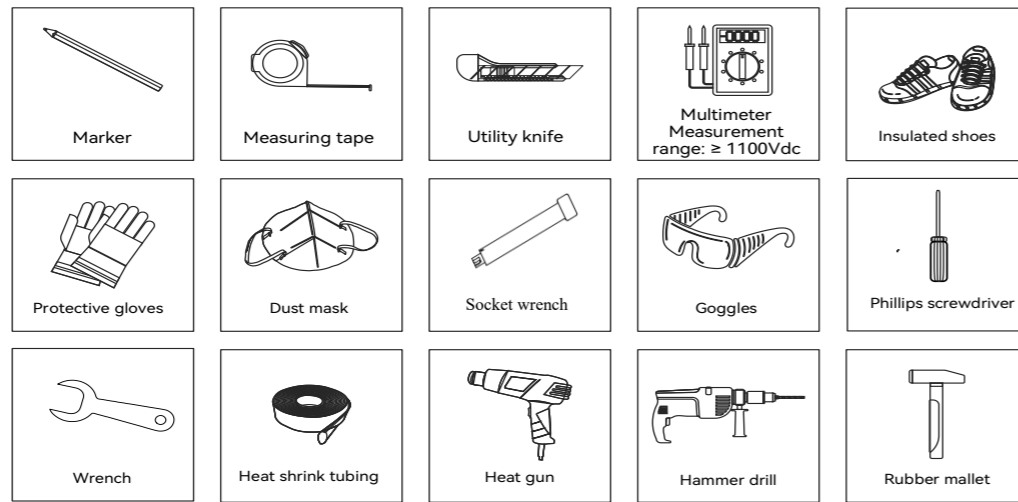

4.3.2 Mounting Procedure

The battery employs either ground mounting or wall mounting.

Ground-Mounted Installation

Before installation, ensure that the ground is flat and there is no inclination.

Step 1: To install the foot cup, you need to screw it down to the base.

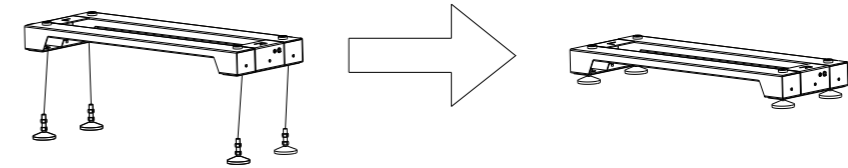

Figure 4.4
Assembling the foot cup

Step 2: Ensure that the base is placed on level ground and kept a distance of 12 to 17mm from the wall. Align the downmost printed horizontal line of the cardboard with the surface of the base and two printed short vertical lines with the two sides of the base. Stick the cardboard on the wall through the double-sided sticky tape on the opposite side of the cardboard.

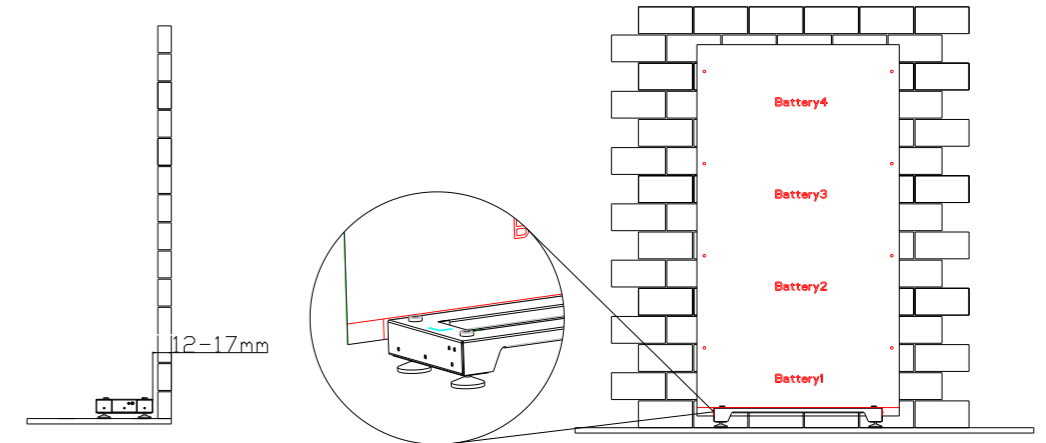

Figure 4.5
Base and cardboard placement

Step 3: Drill holes as the printed hole positions on the cardboard (8mm in diameter and 55mm in depth). Then drive the screw fixing seats into the holes with a rubber hammer.

Note: The number of drilling holes depends on the number of battery packs.

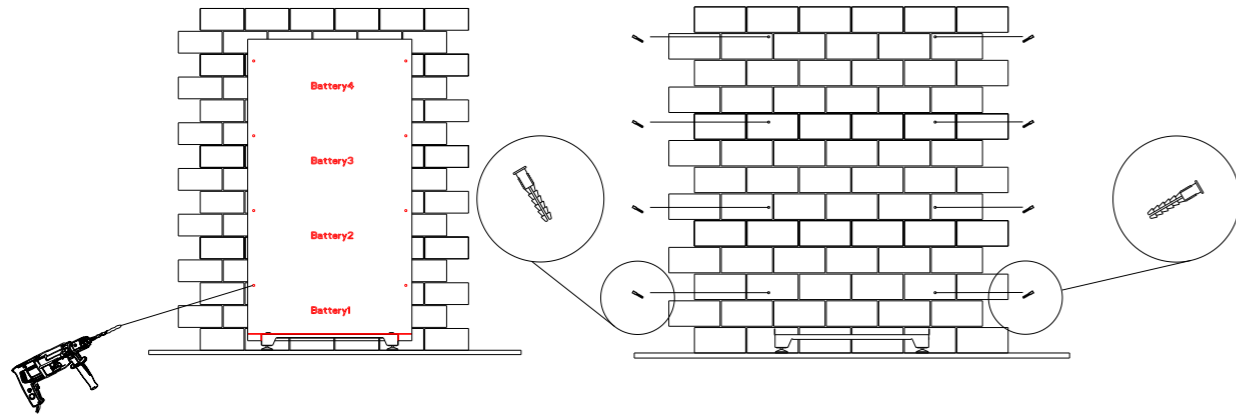

Figure 4.6
Drilling holes and inserting
screw fixing seats on the wall

Step 4: Put the battery pack on the base and fix the battery pack on the base with locking brackets and screws (M4*10).

Step 5: To fix the battery pack on the wall, adjust the fixtures of the battery pack to fit with the screw fixing seats and secure the fixtures on the wall with hexagonal head wooden screws and flat gaskets.

Step 6: Stack the rest of the battery packs, secure the upper one on the lower one with locking brackets and screws (M4*10) and fix the battery packs on the wall with fixtures.

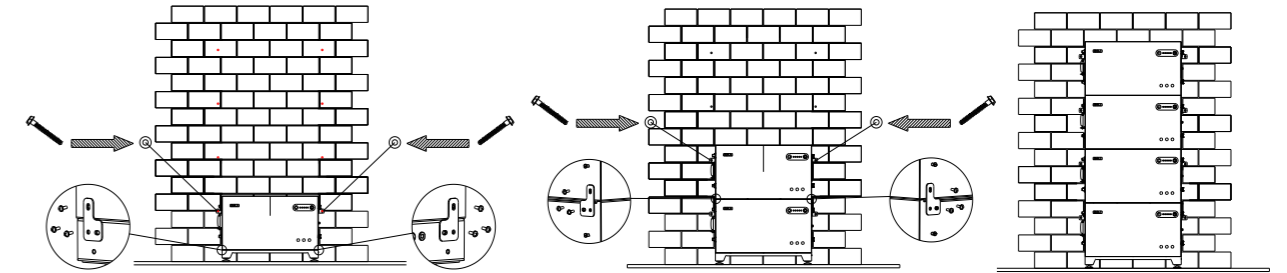

Figure 4.7
Installing the battery packs

Step 7: Remove the locating rubber pad of the topmost battery pack, cover the top coverboard on the top battery pack, align the oval holes of the coverboard with the threaded holes of the battery pack, and fix the board with M4*10 screws.

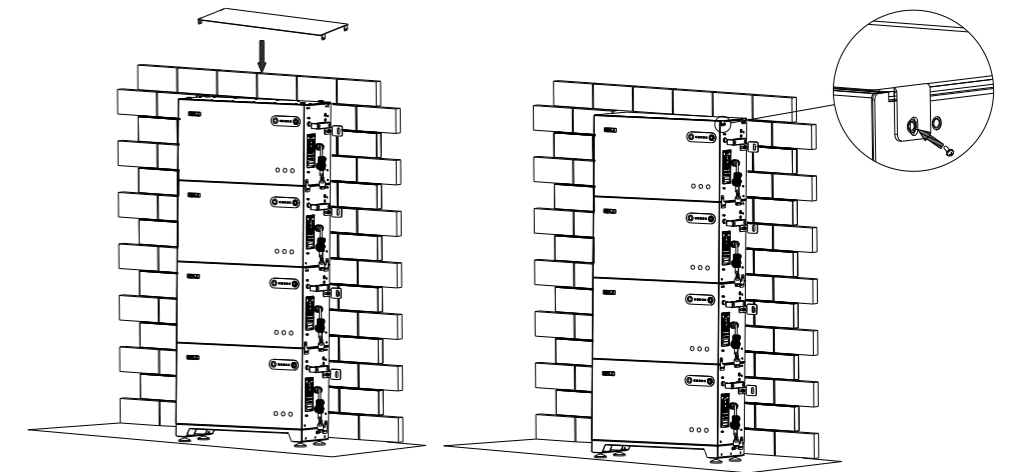

Figure 4.8
Installing the coverboard

Wall-Mounted Installation

Ensure that the wall is capable of mounting screws and supporting the weight of the battery pack before installation. For safety reason, solid wall is recommended for wall-mounted installation, and cavity wall and timber wall are not allowed to install the battery system.

Step 1: Fit the wall bracket onto the wall, and drill holes ($\phi 16$, 105mm in depth) with an electric drill aligned with the mounting holes of the bracket. After drilling holes, use a hammer to drive M12*100 bolts through the bracket into the holes and tighten the bolts with a socket wrench (M12, 230mm in depth) to fix the bracket on the wall.

Note: The customer can decide the mounting height of the wall bracket for their convenience. It is recommended to leave no gap between the bracket and wall.

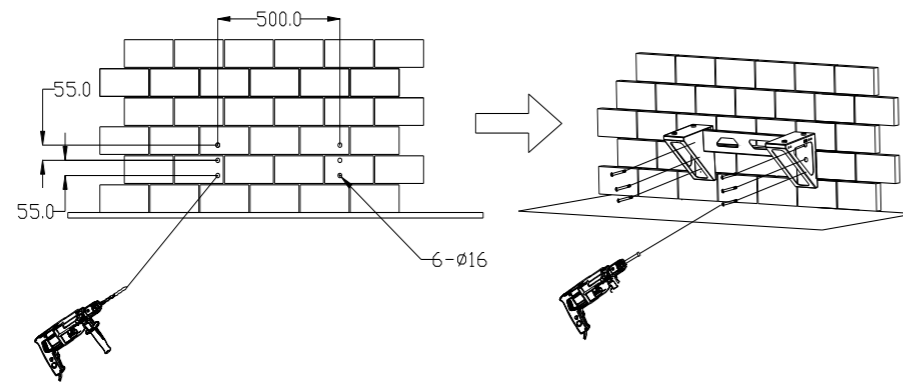

Figure 4.9
Drilling holes and mounting
the bracket on the wall

Step 2: Take out the cardboard from the packaging box. Align the downmost printed horizontal line of the cardboard with the surface of the wall bracket and two printed short vertical lines with the two sides of the wall bracket. Stick the cardboard on the wall through the double-sided sticky tape on the opposite side of the cardboard.

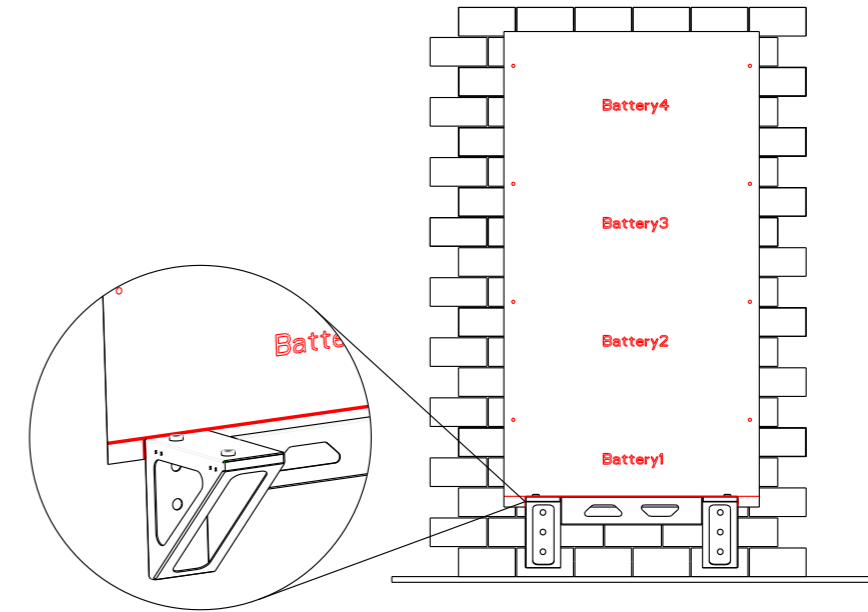

Figure 4.10
Cardboard placement

Step 3: Drill holes at the marks of the wall (8mm in diameter and 55mm in depth). Then drive the screw fixing seats into the holes with a rubber hammer.

Note: The number of drilling holes depends on the number of battery packs.

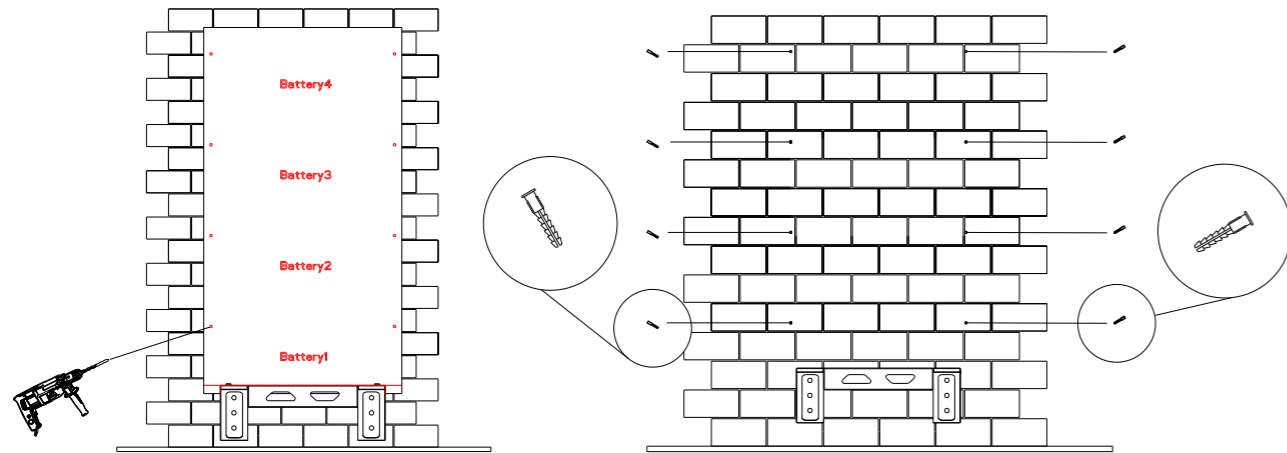

Figure 4.11
Drilling holes and inserting
screw fixing seats on the wall

Step 4: Put the battery pack on the wall bracket and fix the battery pack on the wall bracket with locking brackets and screws (M4*10).

Step 5: To fix the battery pack on the wall, adjust the fixtures of the battery pack to fit with the screw fixing seats and secure the fixtures on the wall with hexagonal head wooden screws and flat gaskets.

Step 6: Stack the rest of the battery packs, secure the upper one on the lower one with locking brackets and screws (M4*10) and fix the battery packs on the wall with fixtures.

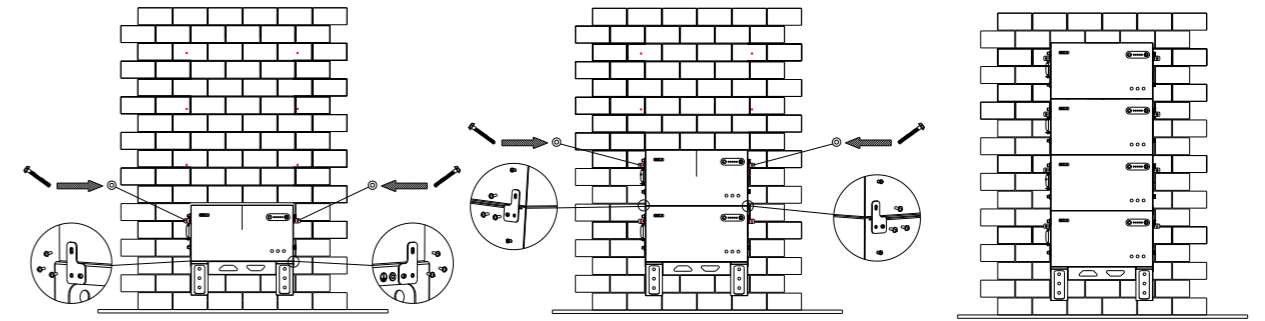

Figure 4.12
Installing battery packs

Step 7: Remove the locating rubber pad of the topmost battery pack, put the coverboard on the top battery pack, align the oval holes of the cover board with the threaded holes of the battery pack, and fix the coverboard with M4*10 screws.

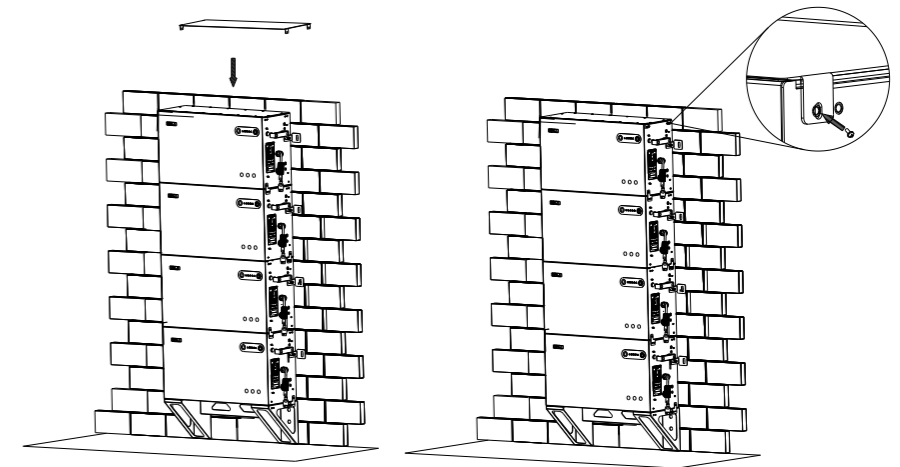

Figure 4.13
Installing the coverboard

5.

ELECTRICAL CONNECTION



5.1 Additional Grounding Cable

Electrical connection must only be operated by professional technicians. Before connection, necessary protective equipment must be employed by technicians, including insulating gloves, insulating shoes and safety helmet.

 WARNING
· Connect this additional grounding cable before other electrical connection.

Note: The additional cable and OT/DT terminal should be prepared by user themselves.

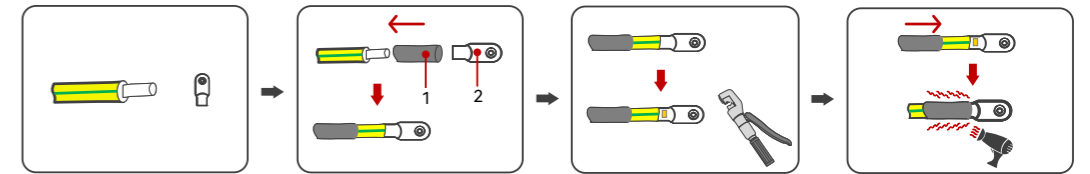

Figure 5.1
Preparing additional grounding cable

1	Heat shrink tubing
2	OT/DT terminal

Remove the screw of grounding port and secure the additional grounding cable. Connect the grounding ports of the two adjacent battery packs with a grounding wire. The grounding port at the bottom of the upper battery pack is connected to the grounding port on the top of the lower battery pack, and the client's grounding wire to the grounding port at the bottom of the downmost battery pack. Connect the grounding cables as the following diagram.

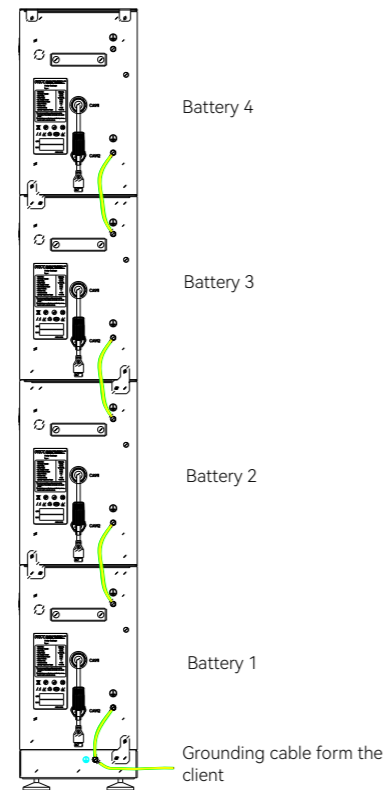

Figure 5.2
Connecting the additional
grounding cable

5.2 Connecting Battery Communication Cable

One stack of battery packs:

Step 1: Connect CAN2 of the upper batteries to CAN1 of the lower batteries.

Step 2: Insert a RJ45 plug to the CAN2 port of the downmost battery.

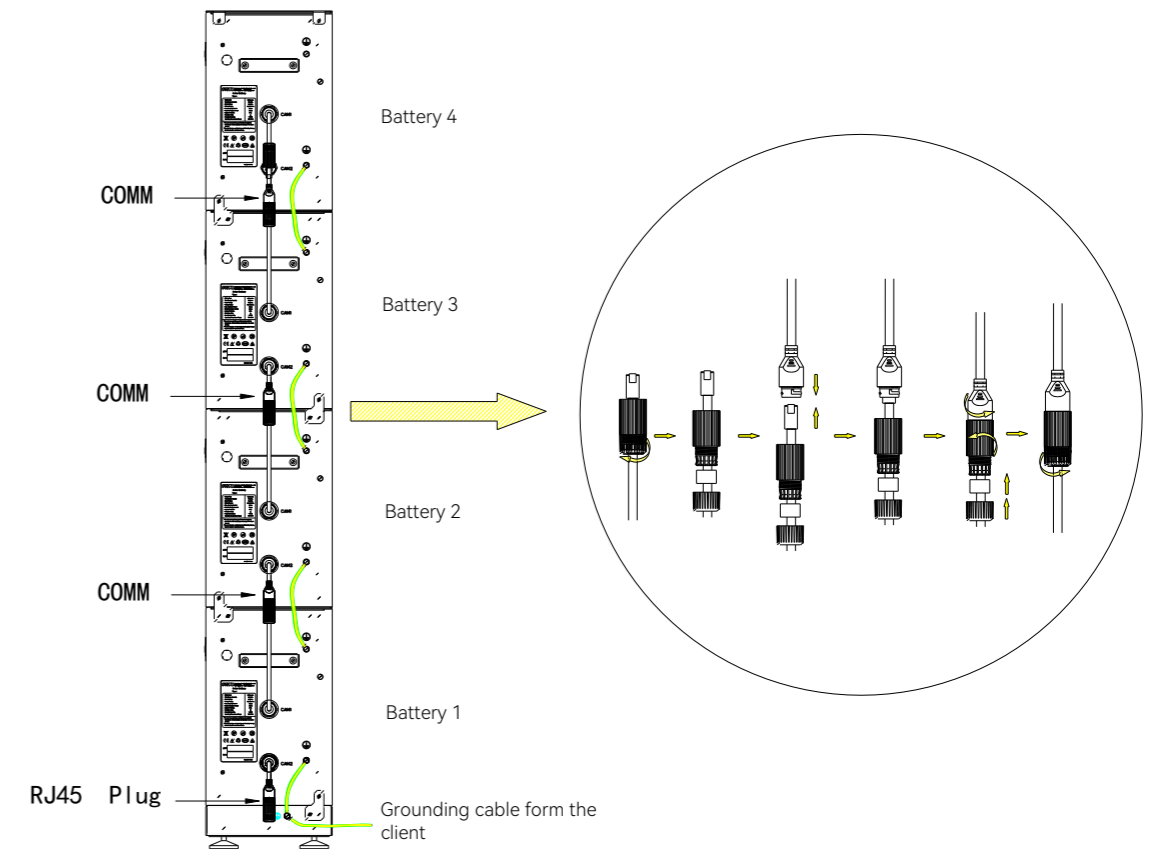

Figure 5.3
Wiring of communication cable
for one stack of battery packs

Two stacks of battery packs:

Step 1: Connect CAN2 of the upper batteries to CAN1 of the lower batteries.

Step 2: Connect the CAN2 ports of the downmost battery packs of the two stacks with a communication cable.

The two sides of the cable should be tightened up for water proofness.

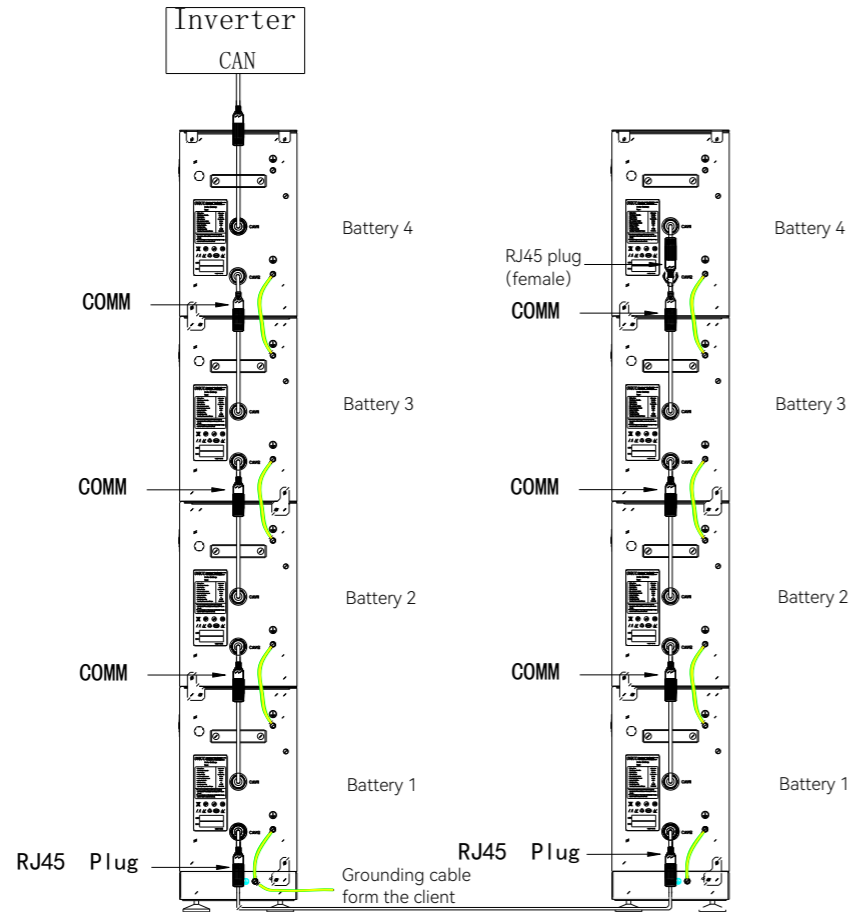

Figure 5.4
Wiring of communication cable
for two stacks of battery packs

Detailed connection methods:

Step 1: Before connecting the communication cable, unscrew the nut of CAN1 cable from the screw shell, and extend the RJ45 plug of CAN1 cable from the screw shell.

Step 2: Insert the RJ45 plug of CAN1 cable into the RJ45 socket of CAN2 cable. Tighten the screw shell of CAN1 cable and the RJ45 socket of CAN2 cable to ensure that the sealant ring of CAN2 cable is clamped by the screw shell, and avoid extruding the sealant ring due to the screw shell being overtightened.

Step 3: Tighten the nut of CAN1 cable with the screw shell. Ensure that the rubber plug seals the outlet hole of the nut and the screw shell.

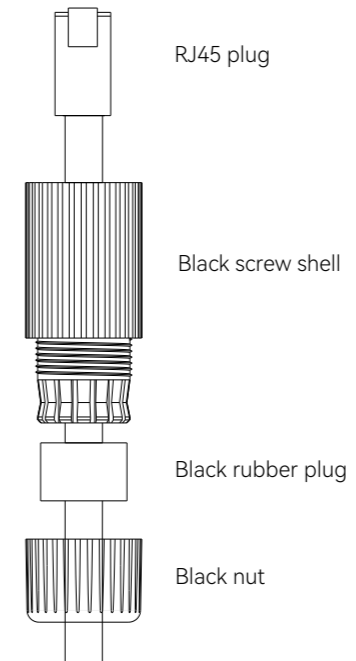

Figure 5.5
RJ45 plug (male) of CAN1 cable

5.3 Connecting Battery Power Cable

WARNING

- Power off the battery system before connecting the power cable to avoid voltage danger
- The electrical connection of B2 series low voltage battery system must be operated by qualified technicians in accordance with local and national power grid standards and regulations.

One stack of battery packs:

Step 1: After the battery packs are stacked, connect the B+ ports of the two adjacent battery packs with the B+ power cable, and connect the B+ port at the bottom of the upper battery pack to the B+ port on the top of the lower battery pack.

Step 2: Connect the B-ports of the two adjacent battery packs with the B- power cable, and connect the B- port on the bottom of the upper battery pack to the B- port on the top of the lower battery pack.

Step 3: Follow steps 1-2 to connect all battery packs.

Step 4: The B+ port on the top of the top battery pack is connected to the positive battery input of the inverter, and the B- port is connected to the negative battery input of the inverter.

Step 5: Cover the B+/B- ports near the bottom of the downmost battery with dust caps.

Two stacks of battery packs:

Step 1 to Step 4: Refer to the steps of one stack of battery packs.

Step 5: Use power cable to connect the B+ port of the downmost battery pack of the right stack with that of the right stack. Use power cable to connect the B- port of the downmost battery pack of the right stack with that of the right stack. For the top battery pack of the stack that has not been connected to the inverter, cover the B+/B- port with dust caps.

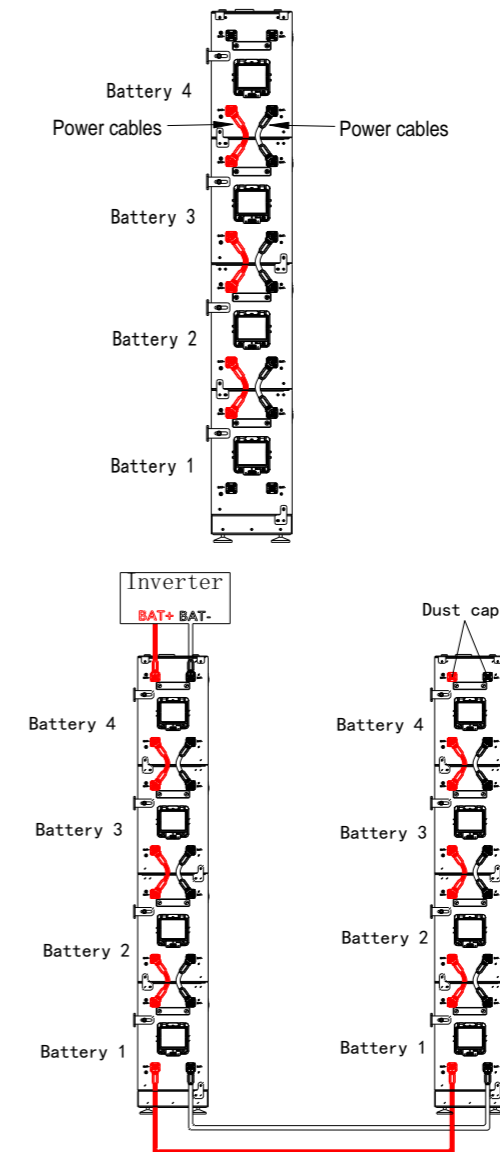

Figure 5.6
Connecting battery power cables

5.4 Connecting Battery to Inverter

Please follow the following diagrams to connect battery and inverter.

One stack of battery packs:

Power cable: Connect the B+/B- port of the top battery pack with the B+/B- port of the inverter respectively with power cable.

Communication cable: Connect the CAN1 port of the top battery pack with the CAN port of the inverter with communication cable.

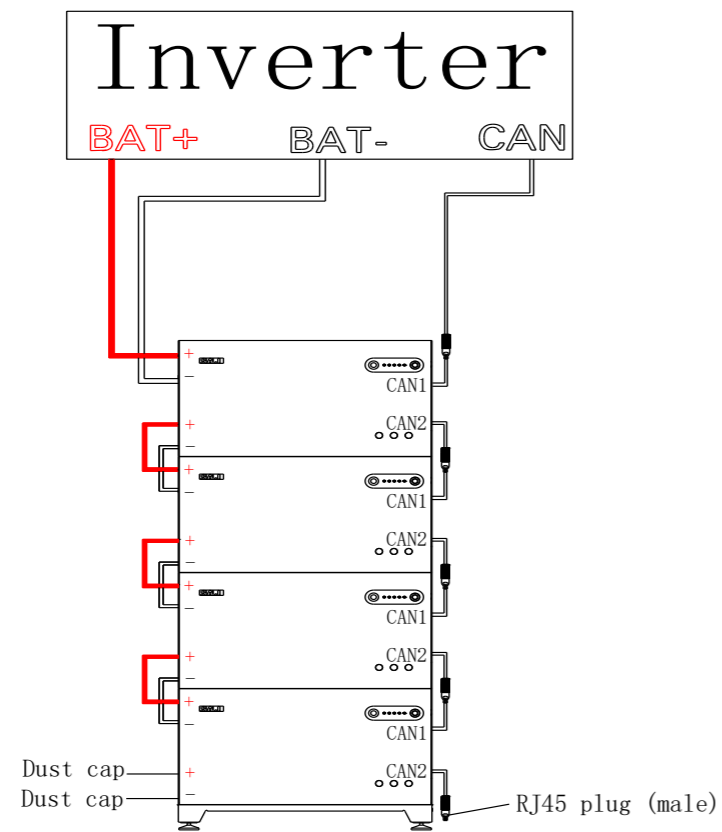

Figure 5.7
Connecting battery system (one stack) to inverter

Two stacks of battery packs:

Power cable: Connect the B+ port of the top battery pack from the left stack with the B+ port of the inverter.

Connect the B- port of the top battery pack from the right stack with the B- port of the inverter.

Communication cable: Connect the CAN1 port of the top battery pack with the CAN port of the inverter with communication cable.

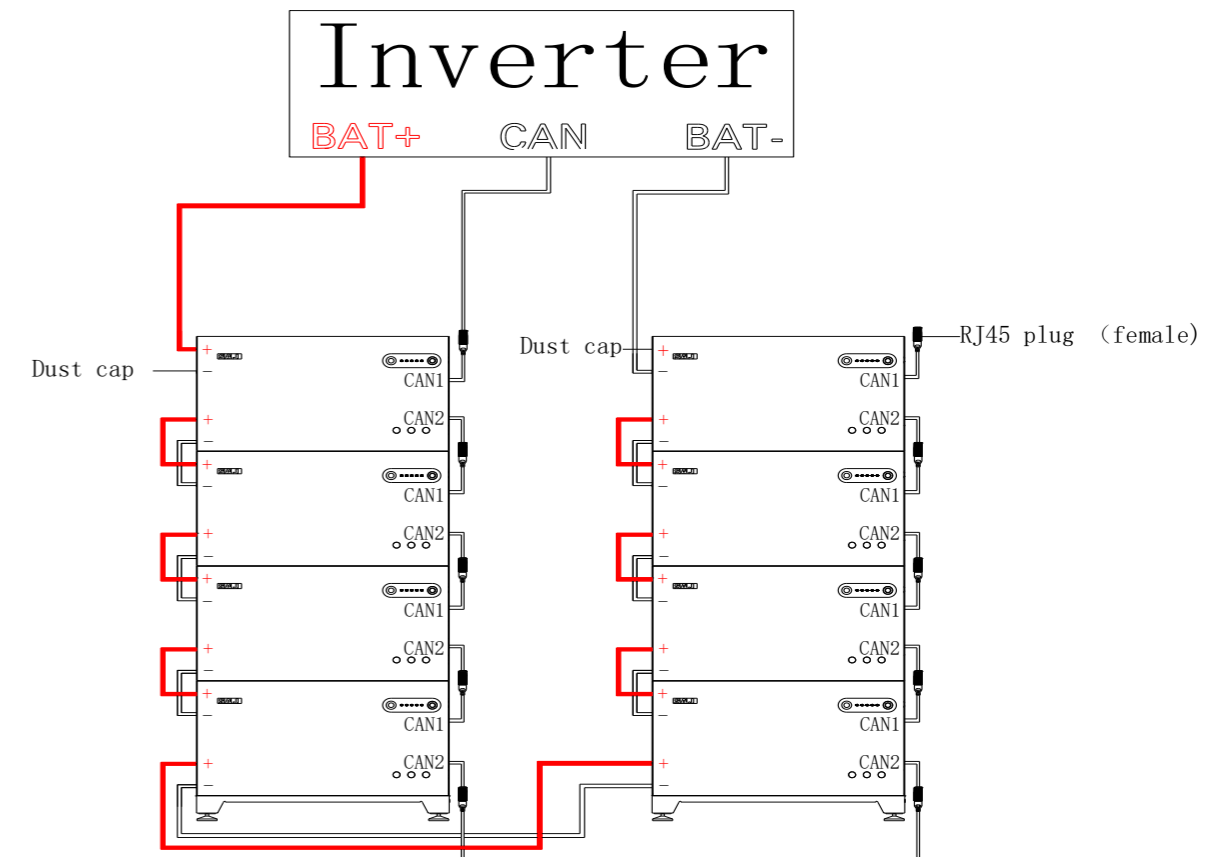

Figure 5.8
Connecting battery system (two stacks) to inverter

5.5 Pinout Description of RJ45

- ① The communication cable is one end crimped, this crimped end is for battery side connection. The other end is for inverter side connection. Customer should crimp the other end of communication cable by themselves.
- ② The pinout of RJ45 is detailed in the table below.
- ③ Confirm that the DC switch is OFF during installation to avoid short circuit caused by wrong operation during battery wiring.
- ④ Please use the battery cable in original package.

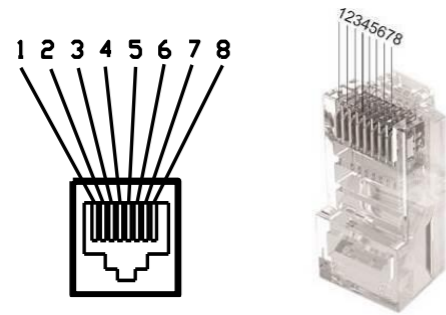

Figure 5.9
Pinout of RJ45

Callout	Color	Name
1	/	Blank
2	/	Blank
3	/	Blank
4	Black	CAN-H
5	Red	CAN-L
6	/	Blank
7	Yellow	RS485-A
8	Green	RS485-B

Table 5.1
Pinout description of RJ45

5.6 Installation of Side Covers

Install the side covers on both sides of the battery module and secure the covers with screws (M4*20) on the battery module.

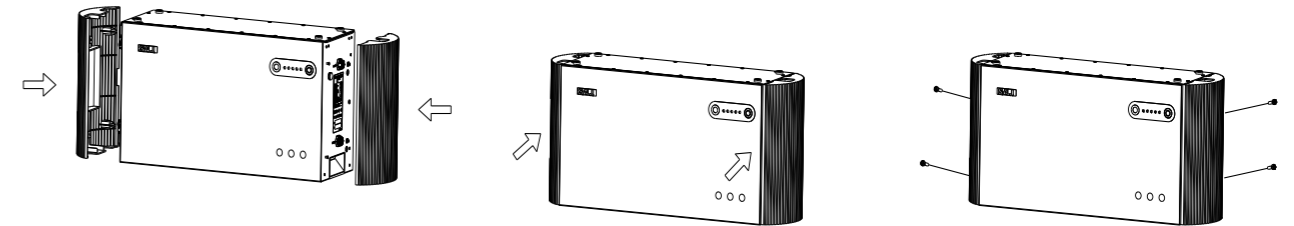

Figure 5.10
Installation of side covers

6.

COMMISSIONING



6.1 Start Up and Shut Down

After the wiring is completed, refer to the inverter manual for system commissioning and operation.

6.1.1 Start Up

Step 1: Turn on the circuit breaker.

Step 2: Press and hold the main switch for 2-3 seconds until the display is on.

6.1.2 Shut Down

Step 1: Press and hold the main switch for 2-3 seconds until the display is off.

Step 2: Turn off the circuit breaker.

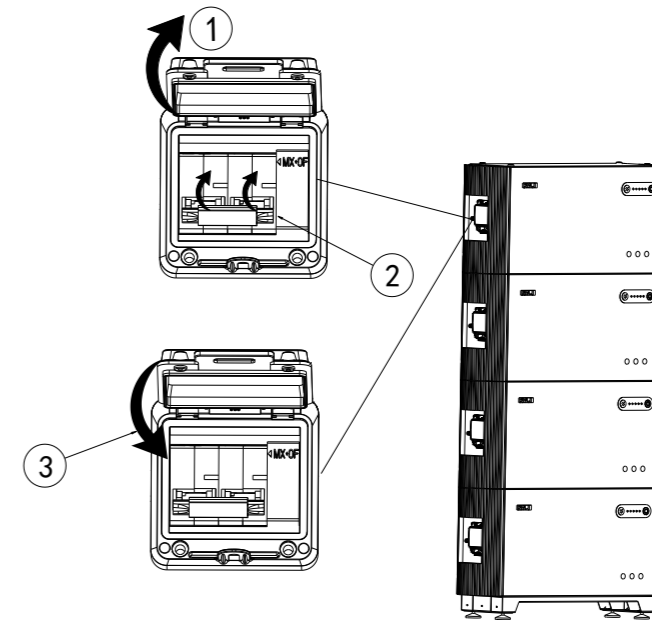

Figure 6.1
Circuit breaker of battery

6.2 Introduction of Display

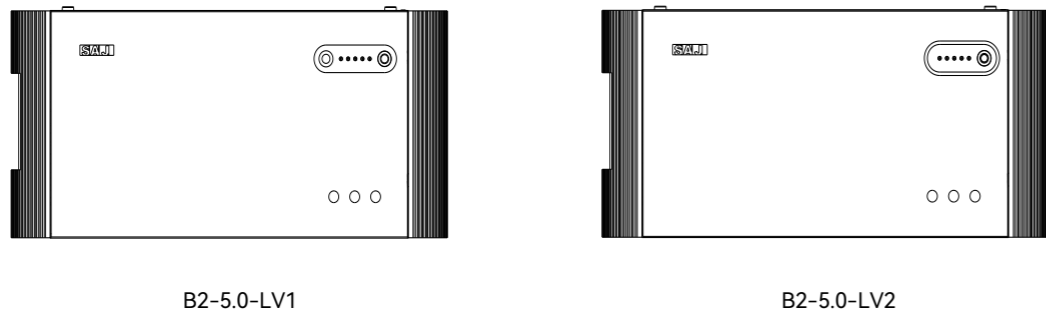

Figure 6.2
Display on the battery

Note: The B2-5.0-LV1 series battery and the B2-5.0-LV2 series battery looks the same except the display. The display of B2-5.0-LV1 series battery has a nonluminous decorative green ring (○) on the left while the display of B2-5.0-LV2 series battery does not.

Display	Status		Description
	Green	Steady on	The battery is in normal state.
		Breathing mode	The battery is in initialization or waiting state.
	Red	Steady on	An error occurs.
		Breathing mode	Software is upgrading in the battery.
	Off		Powered off
	Red	Steady on	State of charge (SOC) < 5%
	Yellow	Steady on	5%≤SOC < 15%
	Green	Steady on	15%≤SOC < 25%

Display	Status		Description
	Green	Steady on	25%≤SOC < 50%
	Green	Steady on	50%≤SOC < 75%
	Green	Steady on	75%≤SOC < 95%
	Green	Steady on	SOC≥95%

Note: One breathing cycle is 6 seconds.

Table 6.1
Interface description

6.3 Commissioning

For eSolar APP downloading and detailed system commissioning information, refer to the inverter manual. Select SAJ for battery brand during commissioning.

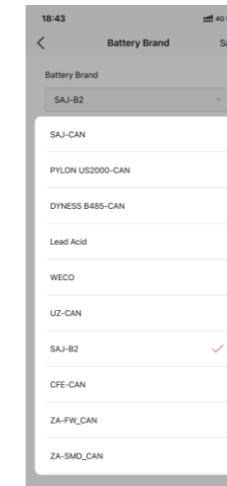

Figure 6.3
Selecting the battery brand

Note: Turn on the circuit breaker and main switch before any operation.

7.

TRANSPORTATION & STORAGE



7.1 Transportation

Lithium batteries are dangerous goods. Passed the test of UN38.3, this product meets the transportation requirements for dangerous goods for lithium batteries. After the installation of the battery on site, the original packaging (contains the lithium battery identification) should be kept. When the battery needs to be returned to the factory for repair, please pack the battery with the original packaging to reduce unnecessary trouble.

Take care of the product during transportation and storage and keep less than 4 cartons of battery in one stack.

7.2 Storage

After purchasing the battery, please store it with following instructions:

- ① Please store it in a dry and ventilated environment, keep it away from heat sources.
- ② Please keep it in an environment with a temperature of -20°C to 45°C , and the humidity less than 95% RH (storage time less than 1 month).
- ③ For long-term storage (storage time less than 6 months), please put it in an environment with a temperature of 0°C to 35°C and the humidity less than 95% RH.
- ④ The battery should be stored in accordance with the storage requirements mentioned above, and the battery should be installed within 6 months since delivered from the factory and used with compatible inverters.
- ⑤ Put the product in a dry and ventilated place for long-term storage. Charge the battery pack regularly every six months (charge 0.2C-1C to 50-60% of the charged battery) to ensure the battery is in optimum performance.

NOTICE

- The battery remains 50% power when it is delivered from the factory.
- The longer the battery is stored, the lower the SOC. When the remaining voltage of the battery fails to reach the startup voltage requirement, the battery may be damaged.
- Judgment condition: Close the battery breaker switch and press the main switch. At this time, if the LED light is solid green, it is running properly. If the LED light is red or off, the battery is not functioning correctly.

The battery cannot be disposed of as household refuse. When the service life of the battery reaches to the

limit, it is not required to return it to the dealer or SAJ, but it must be recycled to the special waste lithium battery recycling station in the area.

7.3 Maintenance

Below is the recommended maintenance cycle. The actual maintenance cycle can be adjusted according to the specific installation environment of this product.

The power station scale, installation location and on-site environment will affect the maintenance cycle of this product. In sandy or dusty environments, it is necessary to shorten the maintenance cycle and increase the frequency of maintenance.

Maintenance performed once a year:

■ Battery module status

Check the following items. Take corrective actions immediately for any abnormal situations:

- Check the battery module and internal devices for damage or deformation.
- Check the internal devices for abnormal noise during operation.
- Check whether the temperature inside the battery cluster is too high.
- Check whether the internal humidity and dust of the battery module are within the normal ranges. If necessary, clean the battery module.

■ Warning symbols

Ensure the warning symbols and label are legible. If necessary, clean them.

■ Wire and cable

Ensure the switch gear and PCS are connected correctly.

■ Corrosion

Check the battery module for internal oxidation or rust.

Maintenance performed once every six months:

■ Switch gear and battery module

Check the following items. In case of nonconformity, take corrective actions immediately:

- Check whether there are flammable objects around the battery module.
- Check whether the battery module is reliably fixed on the wall, and whether any fixing point is corroded.
- Check the switch gear and battery module for damage, paint peeling, oxidation, etc.

■ Wire and cable layout

Before any operation, ensure all internal devices of the battery module are powered off.

In case of nonconformity found in inspection, take corrective actions immediately:

- Check the cable layout for short circuit and compliance with the specifications. In case of any abnormality, take corrective actions immediately.
- Check the battery module for internal seepage of water.
- Check whether the cables are loose, and tighten them according to the aforesaid torque.

■ Grounding

Ensure the grounding is correct.

■ Function inspection

Ensure the current, voltage and temperature in the operation record of the battery module are within the operating ranges.

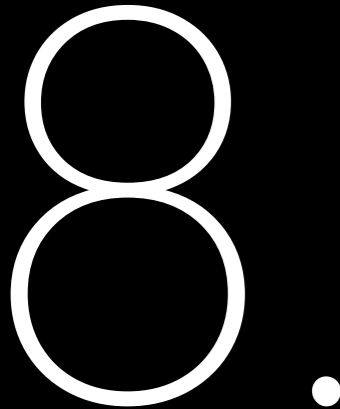

TROUBLESHOOTING & WARRANTY



Troubleshooting

Code	Error Name	Common Cause	Remedy
97	BMS internal communication error	<ol style="list-style-type: none"> 1. Communication error between battery control unit and battery module 2. The RJ45 plug was not installed, therefore battery control unit counted the number of connected battery modules mistakenly. 	<ol style="list-style-type: none"> 1. Check if the communication cable is connected properly. 2. Check if the RJ45 plug is installed.
98	Battery module sequence error	<ol style="list-style-type: none"> 1. Cable connection is wrong. 2. The RJ45 plug was not installed. 3. Communication cable connection is wrong. 	<ol style="list-style-type: none"> 1. Connect the cable correctly. 2. Check if the RJ45 plug is installed. 3. Check if the communication cable is working.
99	Discharge overcurrent protection	Discharging current exceeds the set limit.	Wait until the error is cleared or restart.
100	Charge overcurrent protection	Charging current exceeds the set limit.	Wait until the error is cleared or restart.
101	Total voltage low protection	Total voltage is lower than the set limit.	Force charging the battery
102	Total voltage high protection	Total voltage is higher than the set limit.	Wait until the error is cleared or restart.
103	Single battery module voltage low protection	Single battery module voltage is lower than the set limit.	Force charging the battery
104	Single battery module voltage high protection	Single battery module voltage is higher than the set limit.	Wait until the error is cleared or restart.
105	BMS hardware error	<ol style="list-style-type: none"> 1. Single battery module voltage sensor error 2. Temperature sensor error 3. Current sensor error 	<ol style="list-style-type: none"> 1. Check if battery temperature and voltage sensor cable is in poor contact. 2. Check if the current sensor cable is in poor contact. 3. Replace BMS.

Code	Error Name	Common Cause	Remedy
106	Charging temperature low protection	Battery charging at <0°C	Wait until battery temperature increased and the error is clear.
107	Charging temperature high protection	Battery temperature too high	Wait until battery temperature decreased and the error is clear.
108	Discharging temperature low protection	Battery temperature too low, disconnect relay to stop discharging	Wait until battery temperature increased and the error is clear.
109	Discharging temperature high protection	Battery temperature too high	Wait until battery temperature decreased and the error is clear.
110	Relay error	1. Cathode or anode relay is adhesive. 2. Cathode or anode relay is unable to close.	Replace relay.
111	Pre-charge error	1. Pre-charge relay damaged 2. Pre-charge resistor open-circuit 3. BMS damaged	1. Replace pre-charge relay. 2. Replace pre-charge resistor. 3. Replace BMS.
112	Insulation error	Battery module has electricity leakage	Contact battery supplier.
113	BMS supplier incompatibility	BMS of battery module and battery control unit are incompatible.	Check if the model of battery module and battery control unit are compatible.
114	Battery cell supplier impartibility	Supplier of battery module and battery cell are incompatible.	Check if the model of battery module is correct.
115	Battery cell incompatibility	Battery cells are incompatible.	Check if the model of battery module is correct.
116	Voltage inconsistency	Battery module voltage are inconsistent.	Check if the model of battery module is correct.
117	Circuit breaker is open	1. Circuit breaker is open. 2. Circuit breaker auxiliary contact error	Replace circuit breaker.
118	Temperature difference is too wide	1. Temperature sensor error 2. Battery life span	1. Check if temperature sensor cable is in poor contact.

Code	Error Name	Common Cause	Remedy
119	Voltage difference is too wide(Class II)	1. Sensor cable is loose. 2. Battery life span	1. Check if the voltage sensor cable is in poor contact. 2. Replace BMS.
120	Voltage difference is too wide (Class I)	1. Sensor cable is loose.	1. Check if voltage sensor cable is in poor contact. 2. Replace BMS.
121	BMS over temperature protect	1. Ambient temperature is high. 2. Overload	1. Check if ambient temperature is high. 2. Check if overloaded.
122	Short circuit protect	P+ and P- short circuit	Check if the cable is connected correctly.
123	Total voltage match fail	Connection is wrong	Contact technical support to locate the fault.
124	The system is locked	System is faulty.	Contact technical support to locate the fault.
125	FUSE error protection	FUSE is damaged.	Contact technical support to locate the fault.
126	Voltage on charging port is high protection	Inverter output voltage is high.	Contact technical support to locate the fault.

Warranty

Please go to SAJ website for warranty conditions and terms:
<https://www.saj-electric.com/>