



User Manual

B1-5.1-48

www.saj-electric.com

Content

CHAPTER 1 SAFETY PRECAUTIONS	- 3 -
1.1 SAFETY INSTRUCTIONS.....	- 3 -
1.2 EXPLANATIONS OF SYMBOLS	- 5 -
1.3 EMERGENCY SITUATION	- 6 -
CHAPTER 2 PRODUCT INTRODUCTION	- 8 -
2.1 APPLICATION SCOPE OF PRODUCTS	- 8 -
2.2 SPECIFICATION FOR PRODUCT MODEL.....	- 8 -
2.3 DATASHEET	- 9 -
CHAPTER 3 INSTRUCTIONS FOR INSTALLATION.....	- 10 -
3.1 ITEMS IN THE PACKAGE.....	- 10 -
3.2 INSTALLATION POSITION	- 11 -
3.3 MOUNTING PROCEDURE	- 13 -
CHAPTER 4 ELECTRICAL CONNECTION	- 17 -
4.1 SPECIFICATIONS FOR ELECTRICAL INTERFACE	- 17 -
4.2 BATTERY CONNECTION	- 18 -
4.3 COMMUNICATION INTERFACE	- 26 -
4.4 INSTALL THE RIGHT COVER	- 27 -
4.5 GROUND CONNECTION	- 27 -
CHAPTER 5 COMMISSIONING INSTRUCTIONS	- 28 -
CHAPTER 6 BATTERY MAINTENANCE	- 28 -
6.1 TRANSPORTATION	- 28 -
6.2 STORAGE	- 28 -

CHAPTER 7 CONTACT SAJ	- 30 -
WARRANTY CARD	- 31 -

Chapter 1 Safety Precautions

The User Manual describes system configuration and detailed procedures for installation, operation and maintenance of B1 Series Battery. However, this manual does not include any information about inverter that the battery may be applied to. Please read through the User Manual before using this product.

1.1 Safety Instructions

**DANGER**

- Do not expose the battery to temperatures in excess of 45°C.
- Do not subject the battery to any strong force.
- Do not place the battery near a heat source, such as direct sunlight, a fireplace.
- Keep inflammable and explosive dangerous items or flames away from the battery.
- Do not soak the battery in water or expose it to moisture or liquids.
- Do not use the battery in vehicles.
- Do not use the battery in areas where the ammonia content of the air exceeds 20ppm.

**WARNING**

- Only qualified personnel who has full knowledge of local safety regulations and local standards on battery can install, maintain, retrieve and process this product.
- SAJ electric shall not be liable for any loss or warranty claims arising from any unauthorized change of product which may cause fatal injury to the operator, third party or equipment performance.
- For personal and property safety, do not short-circuit the positive (+) and negative (-) electrode terminals.
- Do not use the battery if it has been damaged.









**CAUTION**

- Do not modify or change any components in the battery.
- Risk of damage due to improper modification

**NOTICE**

- During installation of the battery B1, circuit breaker must be disconnected from the battery pack wiring.
- The battery B1 can only be used as a set with SAJ's AS1 and H1 series storage inverter, otherwise it cannot be used normally.

1.2 Explanations of Symbols

Symbol	Description
	Dangerous electrical voltage The device is directly connected to public grid, thus all work to the battery shall only be carried out by qualified personnel.
	No open flames Do not place or install near flammable or explosive materials.
	Danger of hot surface The components inside the device will release a lot of heat during operation. Do not touch metal plate housing of the inverter and battery during operating.
	Attention Install the product out of reach of children
	An error occurred Read the usage manual to troubleshoot problems
	This device SHALL NOT be disposed of in residential waste Please go to Chapter 8 "Recycling and Disposal" for proper
	CE Mark The device is in compliance with Low Voltage Directive and Electromagnetic Compatibility.
	Recyclable

1.3 Emergency situation

Despite of its careful and professional protection design against any hazards, damage of the battery may still possible. If a small amount of battery electrolyte is released due to a serious damage of the outer casing; or if the battery explodes due to not being treated timely after a fire breaks out nearby, and leaks out poisonous gases such as carbon monoxide, carbon dioxide and etc., the following actions are recommended:

1) Eye contact: Rinse eyes with a large amount of running water and seek medical advice

2) Contact with skin: Wash the contacted area with soap thoroughly and seek medical advice

3) Inhalation: If you feel discomfort, dizziness or vomiting, seek medical advice immediately.

4) Use a FM-200 or Carbon Dioxide (CO₂) fire extinguishers to extinguish the fire if there is a fire in the area where the battery pack is installed. Wear a gas mask and avoid inhaling toxic gases and harmful substances produced by the fire.

5) Use an ABC fire extinguisher, if the fire is not caused by battery and not spread to it yet.

 **Warning**

- If a fire has just occurred, try to disconnect the battery circuit breaker and cut off the power supply first, but only if you can do so without endangering yourself.
- If the battery is on fire, do not attempt to extinguish the fire but evacuate the crowd immediately.

Potential danger of damaged battery:

Chemical Hazard: Despite of its careful and professional protection design against any hazard results, rupture of battery may still occur due to mechanical damage, internal pressure etc., and may result in a leakage of battery electrolyte. The electrolyte is corrosive and flammable. When there is fire, the toxic gases produced will cause skin and eyes irritation, and discomfort after inhalation. Therefore:

- 1) Do not open damaged batteries;
- 2) Do not damage the battery again (shock, fall, trample, etc.);
- 3) Keep damaged batteries away from water (except to prevent an energy storage system from catching fire);
- 4) Do not expose the damaged battery to the sun to prevent internal heating of the battery.

Electrical hazard: The reason of fire and explosion accidents in lithium batteries is battery explosion. Here are the main factors of battery explosion:

1) Short circuit of battery. Short circuit will generate high heat inside battery, resulting in partial electrolyte gasification, which will stretches the battery shell. The temperature reaching ignition point of internal material will lead to explosive combustion.

2) Overcharge of battery. Overcharge of battery may precipitate lithium metal. If the shell is broken, it will come into direct contact with the air, resulting in combustion. The electrolyte will be ignited at the same time, resulting in strong flame, rapid expansion of gas and explosion.

Chapter 2 Product Introduction

2.1 Application Scope of Products

The battery B1 is applied to domestic photovoltaic storage system. The battery is built internally with a battery management system (BMS), which is used to ensure efficiency of the battery and to avoid phenomena of overcharge or over-discharge. The battery employs modular design for easy installation and wiring, and can be used by up to 8 parallel devices. B1 battery is also called slave machine in the following text.

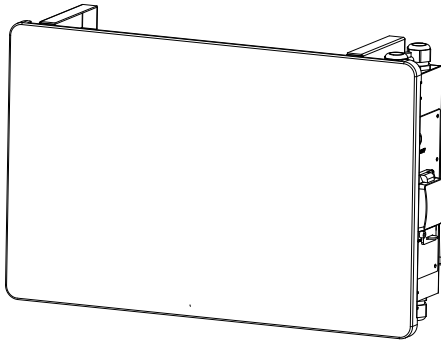

Figure 2.1 B1 exterior overview

2.2 Specification for Product Model

B1 – XX – XX
① ② ③

- ⊕ B1 represents for product name.
- ⊕ XX represents total energy capacity XXKWh, for instance, 5.1 means 5.1kWh.
- ⊕ XX represents voltage grade, for 48 means 48V.







2.3 Datasheet

B1-5.1-48

Type	B1-5.1-48
Electrical Parameters	
Total Energy Capacity[Wh]	5120
Usable Capacity [Wh]	4600
Rated Voltage [V]	51.2
Voltage range [V]	42~58.4
Depth Of Discharge[DOD]	≤90%
Cycle Life	≥6000
Max.Charge Current [A]	60
Max.Discharge Current [A]	60
Physical Parameters	
Battery Type	Lithium-ion phosphate (LiFePO4)
Communication	CAN
Operating Temperature Range	0°C~50°C
Cooling Method	Natural Convection
Ambient Humidity	0-95% Non-condensing
Ingress Protection	IP65
Dimensions[H*W*D][mm]	410*650*186
Weight [kg]	48
Standard Warranty [Year]	5(Standard)/10(Optional)
Applicable Standard	UN38.3、IEC62619

Chapter 3 Instructions for installation

3.1 Items in the package

			
Battery pack		Wall bracket	
			
<p>6* Hexagon head wood screws; 6* Screw Fixing Holders; 6* Washer</p>	<p>2* Power cables</p>	<p>1* Ethernet cable& 2* RJ45 plug</p>	<p>1* User Manual</p>

3.2 Installation Position

3.2.1 The battery size shown as follows

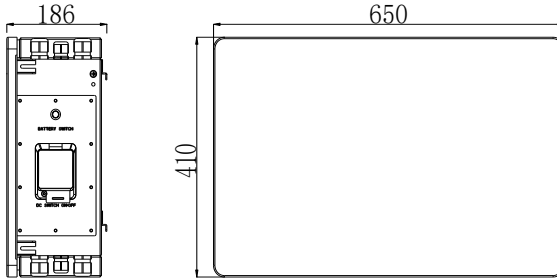

Figure 3.1 B1-5.1-48 exterior and dimension

3.2.2 Installation Position

This device is cooled by natural convection and suggested an indoor installation or an installation under a sheltered place to prevent the battery from exposure to direct sunlight, rain and snow erosion.

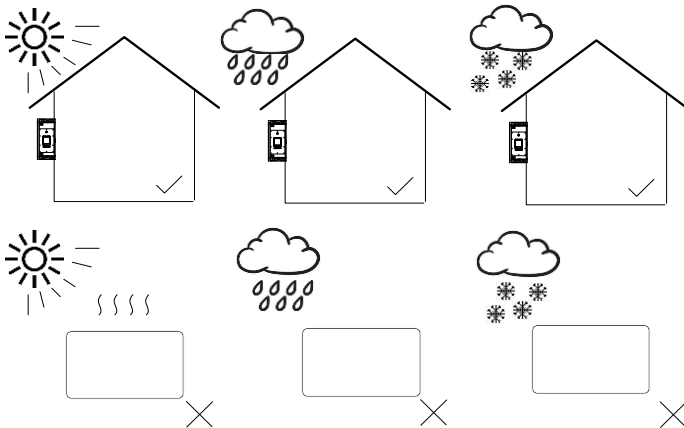

Figure 3.2 Mounting location

3.2.3 Mounting Method

A vertical mounting is recommended and the battery accepts backwards tilt by max.15°. Never mount the battery horizontally or upside down.

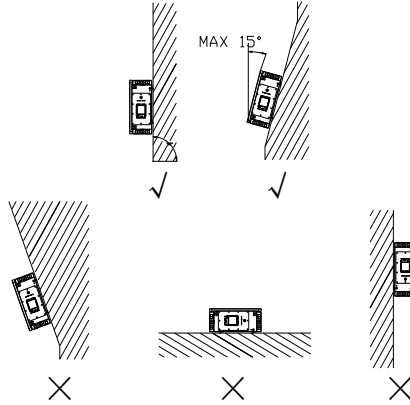

Figure 3.3 Mounting method

Please ensure a good air circulation at the installation area. Because poor air ventilation will affect the working performance of internal electronic components and shorten the service life of the system.

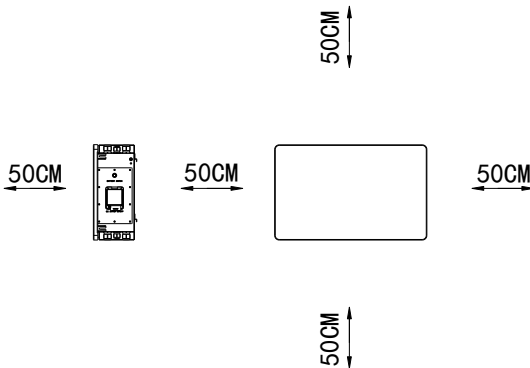

Figure 3.4 Installation position

Note: When installing outdoors, the height of the battery from the ground should be considered to prevent the battery from soaking in water. The specific height is determined by the site environment.

3.3 Mounting Procedure

3.3.1 Positioning the drilled holes for bracket

The battery uses free-standing installation and its position is determined by the drilled holes of bracket, Unit: mm.

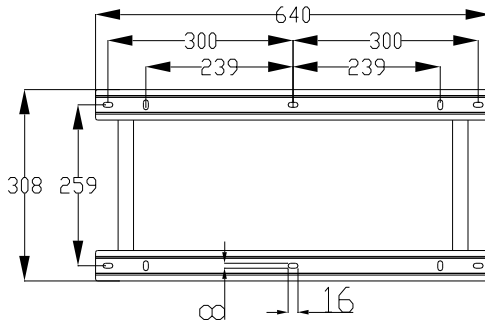

Figure 3.5 Bracket for B1-5.1-48

Make sure that the wall is capable of mounting screws and supporting the weight of the battery pack before installation. Mark the proper positions of mounting bracket and drill holes on those positions (8mm in diameter, 50mm in depth) by using the mounting bracket as a template, and then use a rubber hammer to drive the screw fixing seat into the holes to fix the bracket.

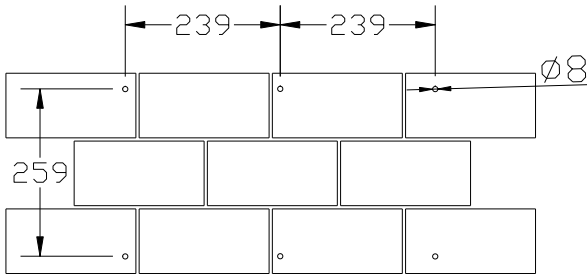

Figure 3.6 Bracket for B1-5.1-48

Fix the brackets in the marked position with hex screws.

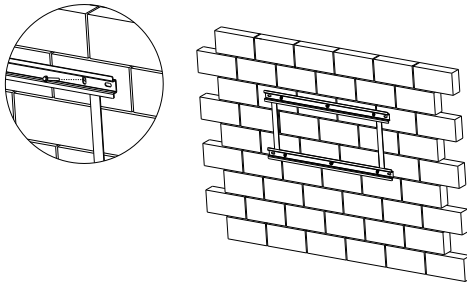

Figure 3.7 Mounting the brackets

Please be careful when installing the device. First remove the nut from the waterproof cable gland, then reapply the cable gland, but do not tighten it, tighten it after inserting the cable. The ports that do not require wiring should remain in their original state.

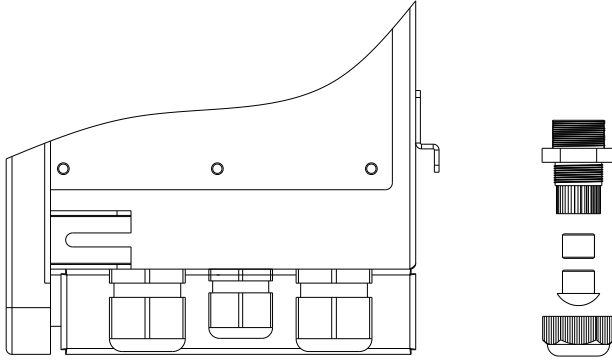

Figure 3.8 Remove plug

Carefully mount the device onto the brackets and make sure the bottom of the device is attached to the brackets.

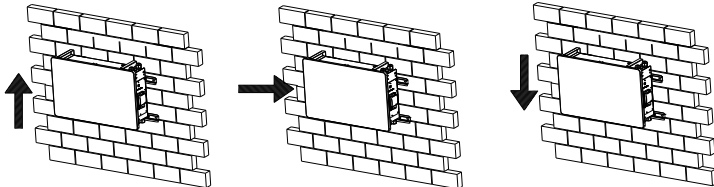

Figure 3.9 Installation of the battery

When several pieces of battery use together and to ensure the completed installation of the device, the clearance between bracket and bracket shall at least meet the $\geq 115\text{mm}$ requirements. Maximum 8 batteries can be in parallel. If equal or more than 5 batteries are connected in parallel, the maximum number of batteries for one column is 4, the rest of the batteries

must be connected in another column.

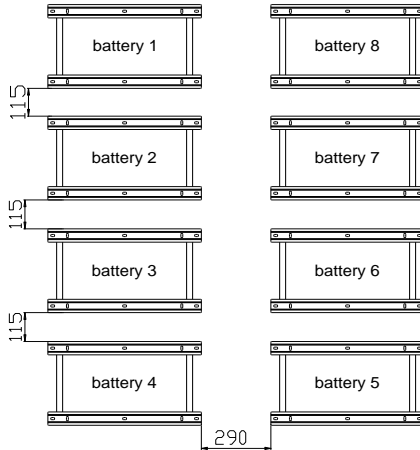

Figure 3.10 Clearance between brackets

In order to have a better connection, please confirm that the cable glands whether have been removed before mounting. During batteries mounting, please install them from bottom to top, i.e. install B1 No.4 firstly, B1 No.3 secondly, B1 No.2 thirdly then B1 No.1 (refer to fig 3.11). Same installation sequence for the second column of batteries, i.e. B1 No.5> B1 No.6> B1 No.7> B1 No.8. At least 2 installers required at site.

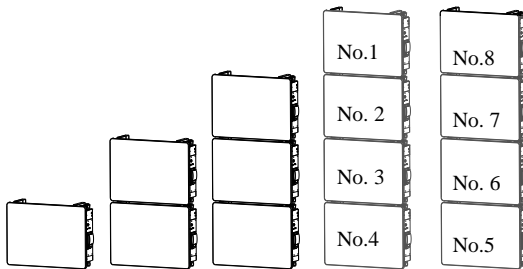

Figure 3.11 Installation of batteries

Chapter4 Electrical Connection

4.1 Specifications for Electrical Interface

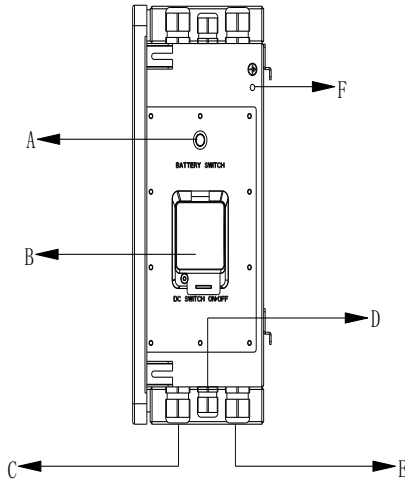

Figure 4.1 B1-5.1-48 Interface

Code	Name
A	BMS switch
B	Battery switch
C	BAT+port
D	BMS COMM port
E	BAT-port
F	Ground

Table 4.1 Interface instruction

4.2 Battery connection

Make sure that the DC switch is OFF, remove the right wiring cover screws and pull out the BMS switch cable then place the cover aside. Unplug the battery switch cable carefully during dismantling.

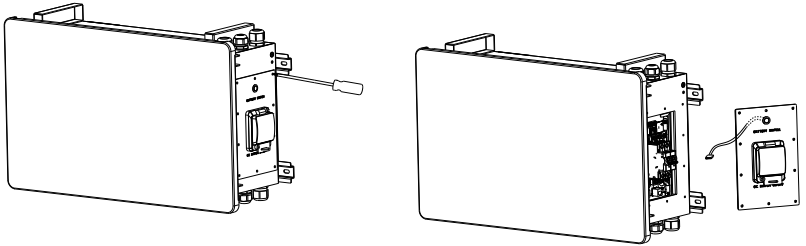
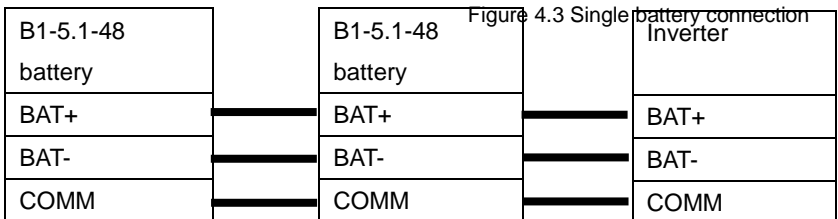

Figure 4.2 Removing wiring cover

Lead power cables through the waterproof glands of the inverter and B1 respectively, make sure the cables are connected correctly (BAT+ of inverter to BAT+ of B1, BAT- of inverter to BAT- of B1 and COMM of inverter to COMM of B1, refer to wiring overview below). Do not reverse the positive and negative terminals. Recommended DC cable conductor core section is 25mm².

Wiring overview between battery and inverter



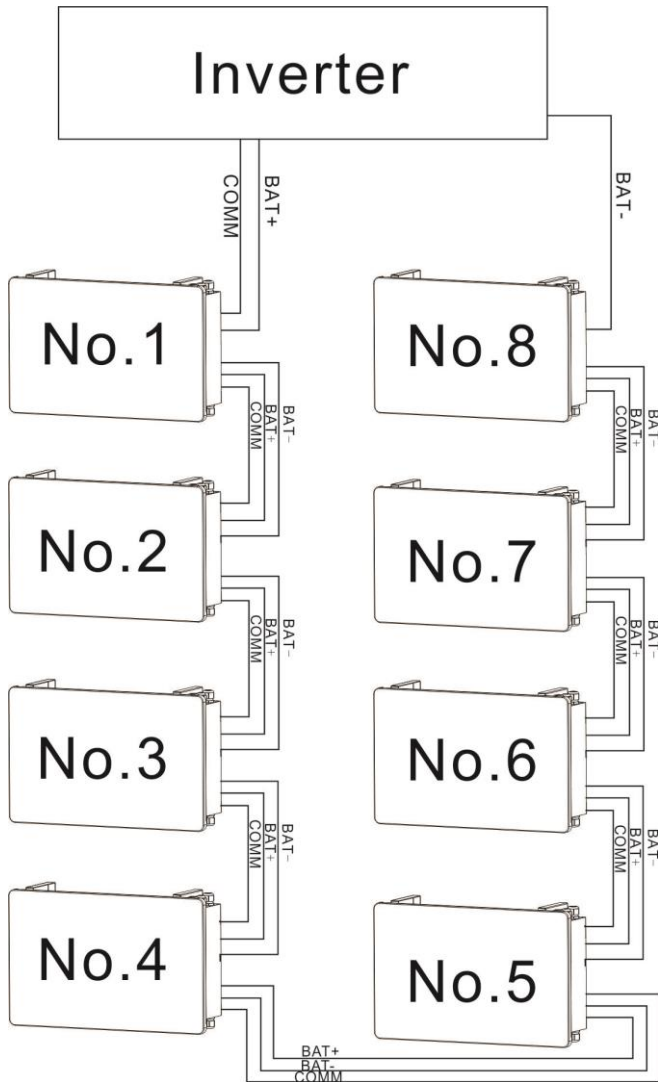

Figure 4.3 Multiple batteries connection overview

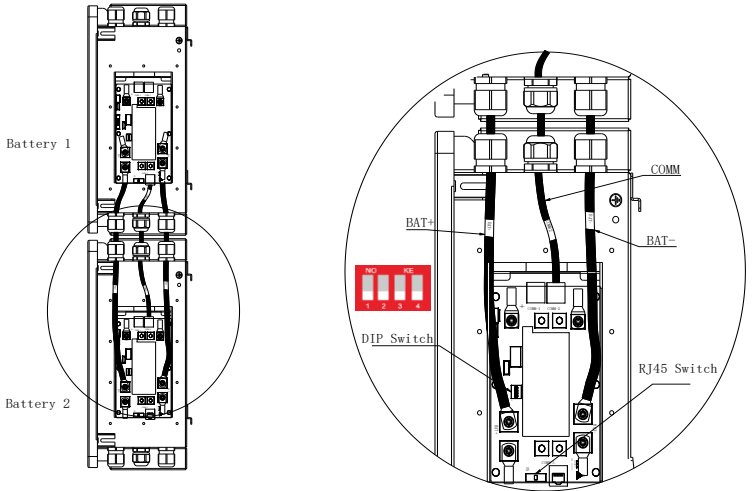

Figure 4.4 Battery 1 to 2 wiring

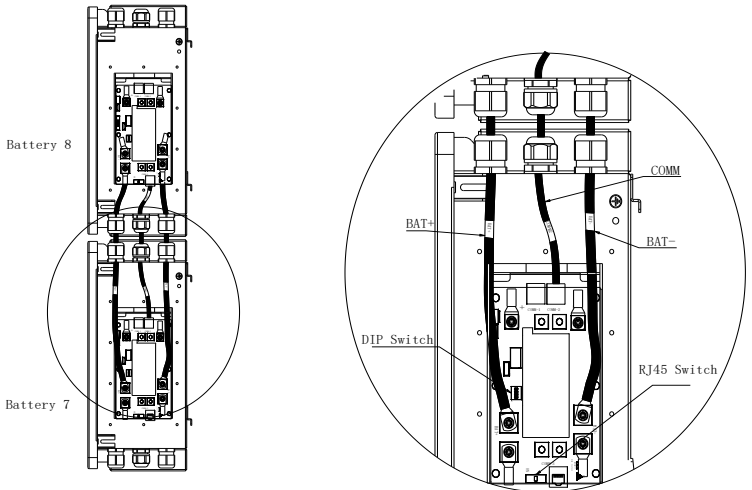

Figure 4.5 Battery 7 to 8 wiring

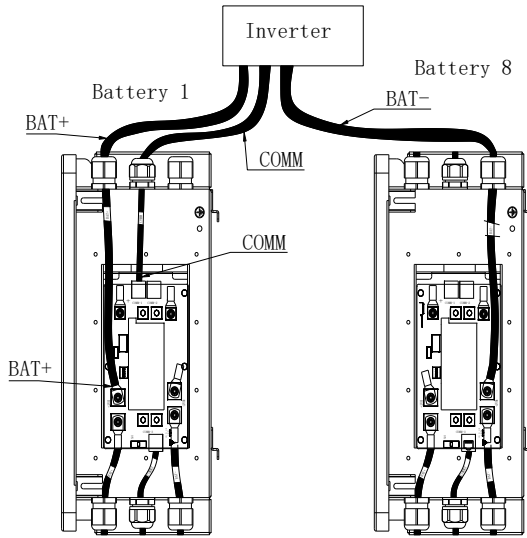

Figure 4.6 Battery to inverter wiring

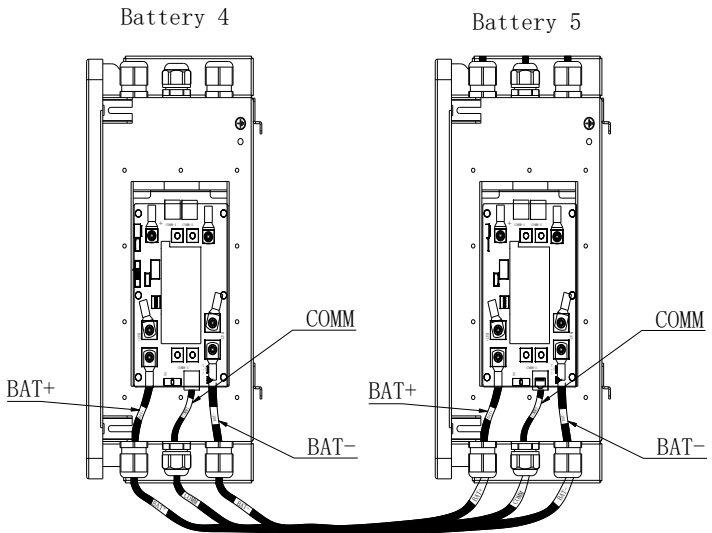

Figure 4.7 Battery wiring for two different battery columns

- Note: 1) One end of the communication cable needs to pass through the waterproof gland before being crimped into the RJ45 Plug, the pinout of RJ45 is detailed in Table 4.2 below
- 2) Confirm that the DC switch is OFF during installation to avoid short circuit caused by wrong operation during battery wiring.
 - 3) Please use the battery cable in original package.

DIP Switch Setting

Please set the DIP switch as below:

1 battery connected

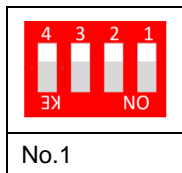

2 batteries connected



3 batteries connected

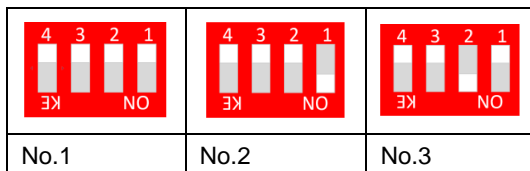

4 batteries connected



5 batteries connected

No.1	No.2	No.3	No.4	No.5

6 batteries connected

No.1	No.2	No.3	No.4	No.5	No.6

7 batteries connected

No.1	No.2	No.3	No.4	No.5	No.6	No.7

8 batteries connected

No.1	No.2	No.3	No.4	No.5	No.6	No.7	No.8

RJ45 Plug

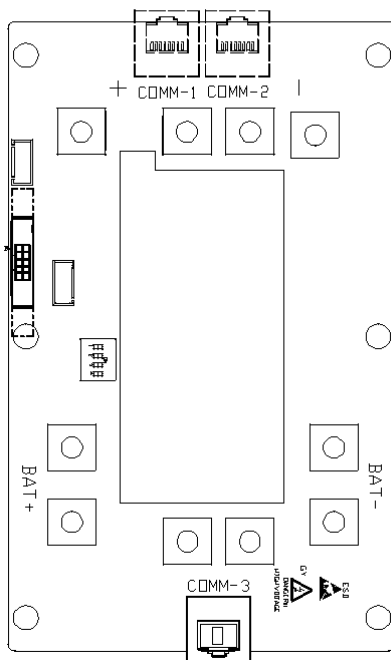

Figure 4.8 RJ45 plug inserted onto COMM-3 port

There is a RJ45 plug being plugged on the COMM-3 port originally, please take it out when you are connecting the batteries, but **DO NOT** take the RJ45 plug out of the very last B1. For example, if you are connecting 4 batteries together, take out the RJ45 plugs from B1 No.1, No.2 and No.3, leave the plug remained on COMM-3 port for B1 No.4.

4.3 Communication interface

Take out the Ethernet cable from the battery packaging.

Note: First pass the cable through the waterproof gland and then crimp the RJ45 plug.

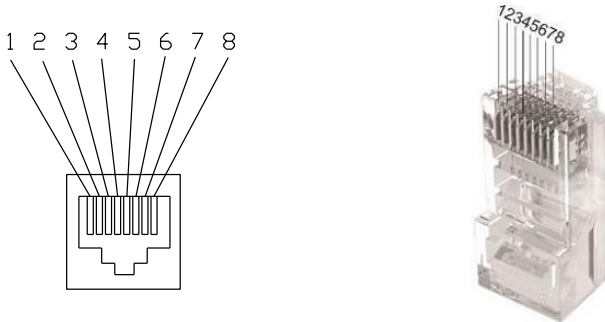

Figure 4.9 Interface definition

Code	Color	Name
1	White-orange	Blank
2	Orange	Blank
3	White-green	Blank
4	Blue	CAN-H
5	White-blue	CAN-L
6	Green	Blank
7	White-brown	CAN-L
8	Brown	CAN-H

Table 4.2 Interface pin description

4.4 Install the right cover

Use the M4 screw previously removed to lock the cover plate. Torque is recommended 14kgf.cm. After installation, please connect Battery Switch cable back to (PCB-CN3) port. And then restore the battery and inverter compartment cover plate.

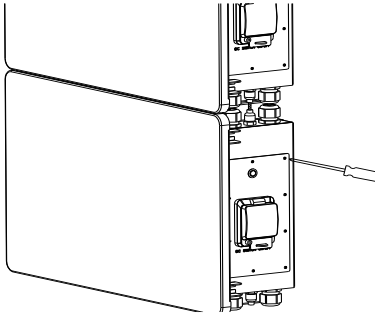

Figure 4.10 Install the right cover

4.5 Ground Connection

Remove the external hex head screw and lead a grounding cable through OT terminal, screw it into the grounding port of inverter enclosure (in clockwise direction) and make sure it is screwed up tightly.

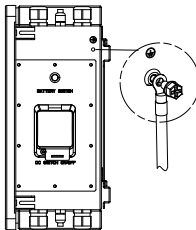

Figure 4.11 Ground connection

Chapter 5 Commissioning Instructions

System commissioning

After the wiring is completed, please refer to the inverter manual for system operation.

Note: Turn on the battery switch and BMS switch when using the B1 battery.

Chapter 6 Battery maintenance

6.1 Transportation

Lithium batteries are dangerous goods. Passed the test of UN38.3, this product meets the transportation requirements for dangerous goods for lithium batteries. After the installation of the battery on site, the original packaging (contains the lithium battery identification) should be kept. When the battery needs to be returned to the factory for repair, please pack the battery with the original packaging to reduce unnecessary trouble.

6.2 Storage

After purchasing the battery, please store it with following instructions:

- 1) Please store it in a dry and ventilated environment, keep it away from heat sources;
- 2) Please keep it in an environment with storage temperature as $-20^{\circ}\text{C} \sim 50^{\circ}\text{C}$, humidity $<85\% \text{ RH}$;
- 3) For long-term storage (>3 months), please put it in an environment with a temperature of 18°C to 28°C and a humidity of $< 85\% \text{ RH}$;

4) The battery should be stored in accordance with the storage requirements mentioned above, and the battery should be installed within 6 months since delivered from the factory and used with compatible inverters;

**Notice**

- The battery remains 40% power when it is sent from the factory.
- The longer the battery is stored, the DOD value is getting larger. When the battery remaining voltage fails to reach the startup voltage requirement, the battery may be damaged.
- Judgment condition: Close the battery breaker switch and press the BMS switch. At this time, if the LED light is flashing, it is running normal. If the LED light is off, the battery is in faulty.

The battery cannot be disposed of as household refuse. When the service life of the battery reaches to the limit, it is not required to return it to the dealer or SAJ, but it must be recycled to the special waste lithium battery recycling station in the area.

Chapter 7 Contact SAJ

Guangzhou Sanjing Electric Co., Ltd.

SAJ Innovation Park, No.9, Lizhishan Road, Guangzhou Science City,
Guangdong, P.R.China.

Web: <http://www.saj-electric.com>

Technical Support & Service

Tel:+86 20 6660 8588

Fax:+86 20 6660 8589

E-mail: service@saj-electric.com

International Sales

Tel: +86 20 6660 8618/6660 8619/6660 0082/6660 0086

Fax: +86 20 6660 8589

E-mail:info@saj-electric.com

Domestic Sales

Tel: +20 6660 0058/6660 0082

Fax: +20 6660 8589

Warranty Card

The installer should fill in the second form while installing the inverter. For warranty claim, please complete the below forms and send this page to SAJ, attached with the Customer's invoice.

For customer to fill in

Name:		
City:	Country:	Zip:
Tel:	Fax:	E-mail:

Information on device

Device type:	Serial No.(S/N):
Invoice No:	Commissioning date:
Fault time:	
Error message (Display reading):	
Brief fault description & photo:	
Signature: _____ Date: _____	



For installer to fill in

Modules used:		
Modules per string:	No. of string:	
Installation company:	Contractor license number:	
Company:		
City:	Country:	Zip:
Tel:	Fax:	E-mail:
Signature: _____ Date: _____		





Guangzhou Sanjing Electric CO., LTD.

ADD: SAJ Innovation Park, No.9, Lizhishan Road, Science City,
Guangzhou High-tech Zone, Guangdong, P.R.China (Zip: 510663)

Tel: +86 20 6660 8588 Fax: +86 20 6660 8589

Web: <http://www.saj-electric.com>

Edition No: V2.0