

A worker wearing an orange hard hat with the DMEGC SOLAR logo, a green long-sleeved shirt, a high-visibility orange safety vest, and yellow gloves is working on a solar panel. The worker is leaning over the panel, which is mounted on a metal frame. The background shows a blurred outdoor setting with trees and a building.

# PV Modules Unloading & Unpacking Manual

**Hengdian Group DMEGC Magnetics Co., Ltd.**

Hengdian Industrial Area, Dongyang City, Zhejiang Province China

Tel: +86-579-86310330

E-mail: [solar@dmegc.com.cn](mailto:solar@dmegc.com.cn)

# Contents

1. Unloading Instruction .....	3
1.1 Forklift handling precautions .....	3
1.2 Notes for container handling.....	4
1.3 Unloading platform requirements and precautions .....	4
2. Method 1- Hoarding Unpacking Process Steps.....	5
3. Method 2- U-Shaped Unpacking Process Steps.....	6
4. Packaging Specification.....	7
Annex .....	7



## 1. Unloading Instruction

This manual is for DMEGC solar PV module unloading instructions. To ensure the safety of unloading of PV modules, please read this manual carefully.

### 1.1 Forklift handling precautions

- In the process of unloading, the forklift should be selected reasonably according to the size and weight of the goods. If the fork length is less than 3/4 of the size of the goods, extension sleeves should be fitted on the forks before the assembly is forked, in order to avoid the packing container dumping when moving the forklift, theoretically, the fork length shall not be less than 1670mm (Figure1);
- when unloading cross-loading modules, special command is required to ensure that the forklift does not exceed the modules, and prevent damage to adjacent modules when fork is raised or placed due to excessive length of forklift arms (Figure 2);
- The load of forklift shall not be less than 3.5 tons;
- When the forklift is loaded with modules, the spacing between the two forks should be adjusted as required. The load of the two forks should be balanced without deflection. One side of the assembly box should be close to the retainer (Figure3);
- Avoid sharp objects (such as forklift pallet forks) contact or collision with module box body parts, so as not to damage the internal modules (Figure 4);



Figure1



Figure 2

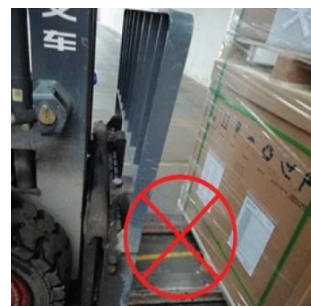

Figure3



Figure 4

- Unloading process, except forklift operator, others should be kept at a safe distance from range, ensure the safety of personnel;
- During loading and unloading, special command is required to avoid failure and making modules down;
- When using a forklift to move palletized packing boxes to the operation area, the forklift shall be slowly and steadily lifted and put down gently during loading and unloading, and the modules shall avoid turbulence and violent vibration during transportation.

### 1.2 Notes for container handling

- During the fork out of the modules, it is allowed of 2~3cm spacing between modules and box walls or adjacent modules, and then move back slowly to prevent the carton from being damaged by friction between modules and box wall or adjacent pallets (Figure 5);
- When the goods go out of the container port, please slow down and lower the height of the forklift arm from the ground (it is recommended to close to the bottom plate to reserve enough space for the top), pay attention to the distance between the bottom of the goods and the top of the container, prevent the goods from colliding with the top of the container, and ensure that the whole pallet module is safely removed from the container (Figure 6);



Figure 5

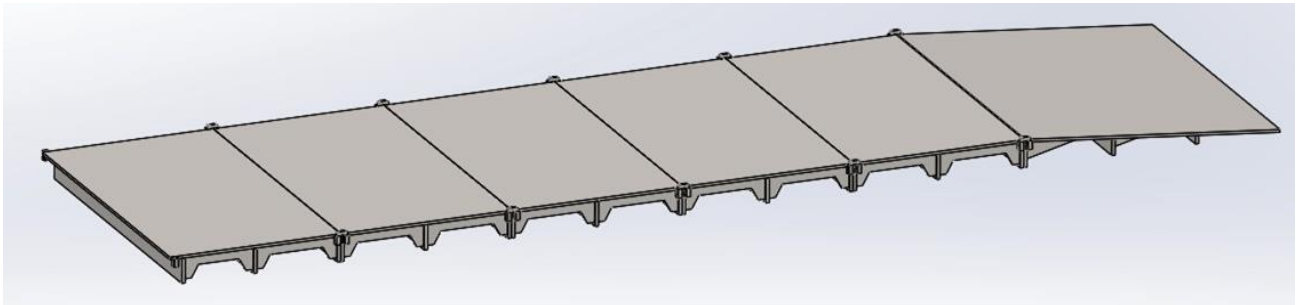

Figure 6

- If the modules need to be temporarily stored after unloading, it is recommended to keep sufficient space between each pallet to avoid scratching the carton or pallet during the second transfer.

**1.3 Unloading platform requirements and precautions**

- Unloading Tools: Forklift/Unloading platform/Unloading pad tooling  
If the container is unloaded on the unloading platform, it is required to be used with the unloading platform or tooling.



- The height of the unloading platform and the height of the unloading tooling should be kept at the basic level with the bottom of the container (loading bottom plate), and the height tolerance should be controlled within  $\pm 10\text{mm}$ .

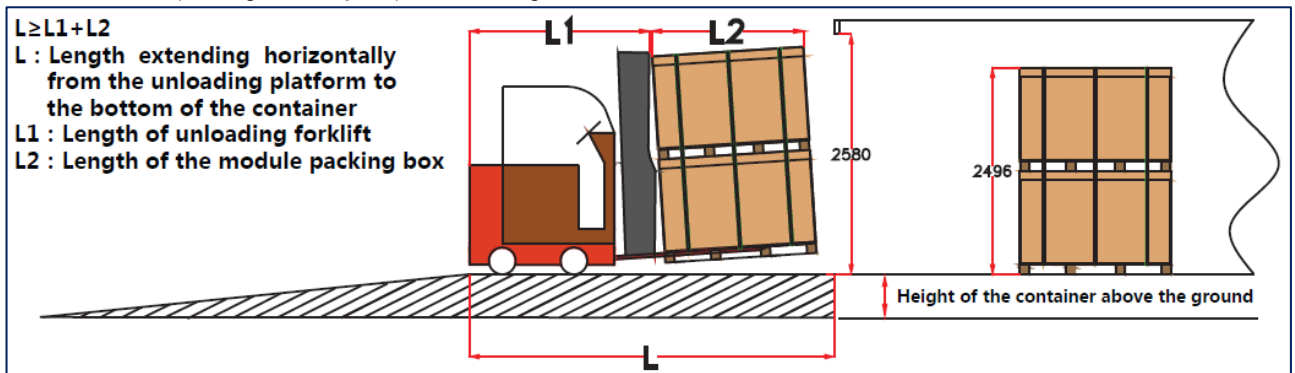

- When the container is unloaded:  
When using the fuel forklift, adjust the height of the forks from the ground, the forks into the short side of the pallet, after the forks into the bottom, lift the modules at an appropriate height (the tilt Angle required to lift the modules  $< 2^\circ$ ), the smaller the distance from the ground when the forklift out of the container door, ensure that the height of the forks from the ground and the distance from the goods to the top of the container is not more than 80mm; The arm length of the forklift mechanical arm is required to lift the modules from the short side of the pallet with a fork (the height of the forklift is required to be  $\leq 40\text{mm}$  from the ground), and the modules are moved out slowly.  
If the modules are unloaded from long side forks, fuel oil forklifts are needed to unload.

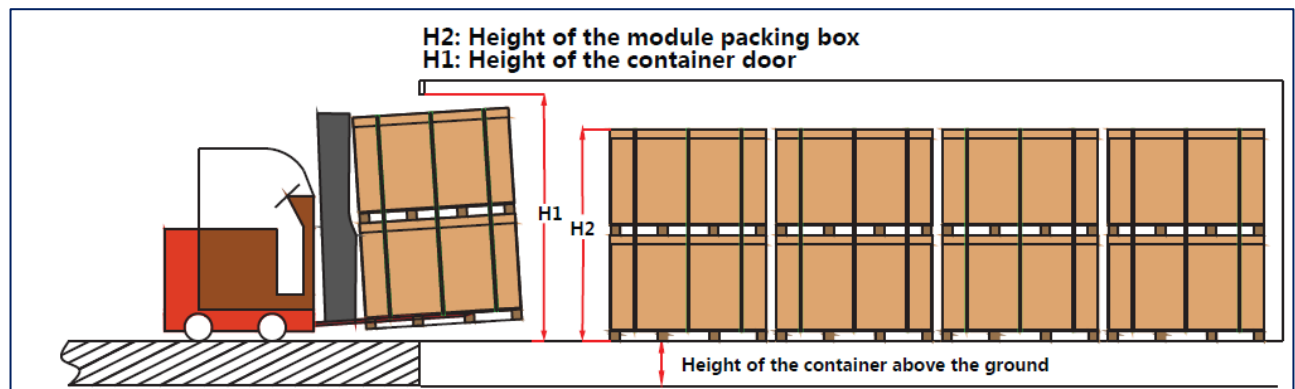

**2. Method 1 Hoarding Unpacking Process Steps**



1. Remove the stretch film



2. Remove all straps



3. Remove top cap



4. Remove surrounded pallet carton sleeve



5. Remove internal straps and tapes.  
(recommend to work in pairs here)



6. Gently put modules against immovable object.











7. Prepare another pallet with a back cardboard.



8. Handle modules individually to another pallet.

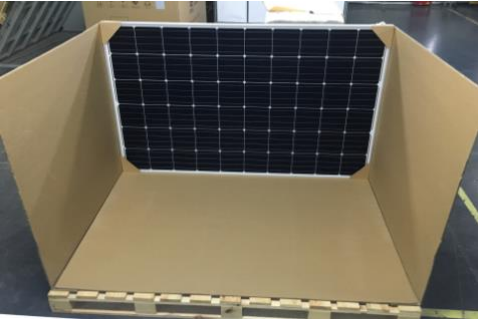

**3. Method 2 U-Shaped Unpacking Process Steps**

	
<p>1. Remove the stretch film.</p>	<p>2. Remove all straps.</p>
	
<p>3. Remove the upper cover and side panels.</p>	<p>4. Tear off the first module's tape. After confirming that the tape with second module is well pasted, remove it.</p>
	
<p>5. Remove modules one by one until the last.</p>	<p>6. Unload the last module.</p>
	
<p>7. Remove the bottom pad.</p>	<p>8. Organize and fold the carton.</p>

**4. Packaging Specification**

Frame height	Frame corner	Quantity/pallet
30mm	kraft paper corner	36 pcs
35mm	kraft paper corner	31 pcs
40mm	kraft paper corner	27 pcs

\*Two types (Hoarding and U-Shaped Unpacking) are both applicable.

**Appendix**

For safe practice, pallets need to be placed in front of a fixed object which shall be able to withstand the weight and have a non-sensitive surface. Anti-falling shelf could be applied for the same purpose in some cases which fixed object is unavailable, as bellowing drawing.

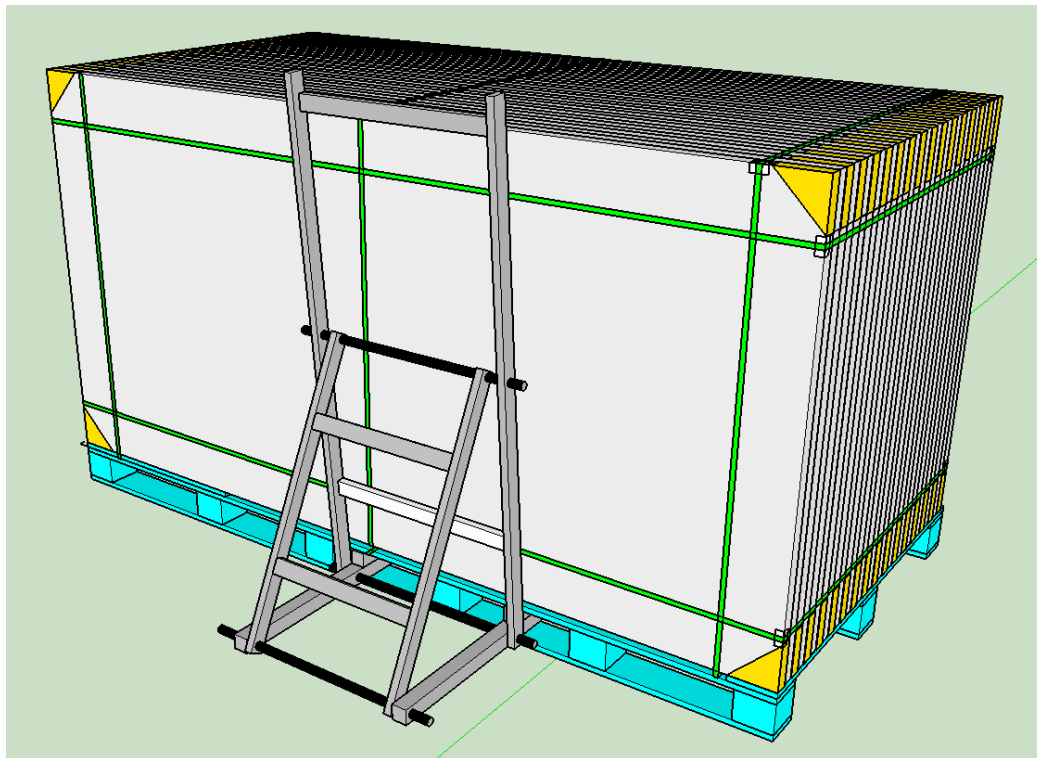

Anti-falling Shelf (for example)